



NEW HOLLAND

B90_B B90_{BLR}



NEW TIER 3A ENGINE

MECHANICAL OR PILOT "COMMAND CONTROLS"

HIGH FRONT LOADER PERFORMANCE



NEW HOLLAND

CONSTRUCTION

BUILT AROUND YOU

B90B

NEW CNH TIER 3A MECHANICAL ENGINE

- High torque at low r.p.m.
- Higher reliability
- Longer lifespan

BEST AVAILABLE HYDRAULIC SYSTEM

- Load sensing, closed centre
- Maximum power available where needed
- Simultaneous movements under every load

COMFORT & SAFETY

- Outstanding spacious operator cab
- All-round cinemascope visibility
- Choice of backhoe: piloted or mechanical



EASY MAINTENANCE AND SERVICING

- New tiltable engine hood for wide, easier ground level access to main components
- Automatic belt tensioner
- Extended oil change intervals

POWERFUL & COMFORTABLE TRANSMISSION

- Powershuttle 4x4
- Quick and smooth direction change
- Enhanced traction force



B90B POWER F

NEW TIER 3A MECHANICAL ENGINE



This new CNH Tier 3A mechanical engine is a prime example of our simple yet high performance technology. As a matter of fact simple, being a mechanical type engine, does not mean that it is a low performer. In fact this power plant's performance - in terms of power output balanced to the application requirements and maximum torque at lower engine revolution - is at the top of it's class. Moreover, the well known mechanical concept is a guarantee of robustness which goes side by side with high reliability and long lifespan. In other words: reduced operating costs and high resale value.

OR PRODUCTION



This engine, with its high torque at low r.p.m. combined with its superb and environmentally friendly performances, makes the B90B particularly suitable for work in urban or populated areas.

A new efficient, durable and economic engine which contributes to a reduction in operating costs, thereby increasing your profit.

B90B INTELLIGENT

LOAD SENSING - CLOSED CENTRE MAXIMUM POWER WHERE NEEDED

The B90B features an **integrated** Hydraulic and Steering System. It consists of two gear type pumps mounted in series with a total delivery of 160 l/min, **Load Sensing** regulated and working at a maximum pressure of 210 bars. When the machine is steering, the steering wheel first activates the Orbitrol steering valve, then - via a priority valve - the increased flow required for faster steering effect is diverted from one of the two hydraulic gear pumps.



FRONT LOADER

If the operator is using the front attachment, when required, a special button on the new loader control lever disconnects the transmission so that total engine power is utilised as hydraulic power on the front loader for maximum productivity and efficiency.



The **handle on the loader control lever**, includes:

- a “rocker”, to proportionally control the additional hydraulic function. It allows, for example, use of the 4-in-1 bucket as a pincer, thus dramatically expanding the New Holland backhoe loader’s flexibility
- the transmission disconnect button to utilise the optimum available hydraulic power on the front attachment for maximum productivity and efficiency.

BACKHOE

If the backhoe is in operation, thanks to its **Closed Centre** main control valve, the hydraulic system delivers its power when and where it is needed, while simultaneous movements are allowed independently from power required and engine r.p.m., for maximum performance, faster cycle times and maximum production.

NT HYDRAULICS



HED (Hydraulic Extending Dipper)

A HED (Hydraulic Extending Dipper) is available as an option for maximum reach, digging depth and loading ability whilst optimising the special New Holland design of the complete backhoe. The New Holland backhoe features a strong box section boom and a narrow dipper, so visibility is excellent down the length of the boom to the bucket at all digging depths. Finally, the externally mounted "in line" cylinder design contributes to visibility whilst providing the best utilisation of hydraulic force for maximum efficiency.

B90B DOMINANT



4x4 POWERSHUTTLE TRANSMISSION

The synchronised, four speed modulated PowerShuttle transmission enables operators to shuttle between forward and reverse quickly and smoothly. This eliminates shock load in the driveline components, increasing durability, enhancing operator comfort and giving safer control of load handling.

E THE GROUND



The transmissions, fitted on the B90B, is designed to better match the torque of the engine. Efficiently translating the demands of the operator, the new engine provides higher traction when required. This means shorter cycles and superior pushing capability in front loader operations, thus providing higher productivity and customer profit.

Enjoy the



power



B90B EASY MAI

EASY ACCESS TO ALL SERVICE POINTS

The B90B is designed for simple and easy maintenance and service procedures, thanks to its new tiltable engine hood which grants excellent ground level access to all the most important components. Easy and regular maintenance of the machine, such as control of air filter and so on, can only improve durability and reliability, already designed and built-in by New Holland engineers.



NTENANCE



ONE LOCATION CHECK POINTS

On the machine's left side, just above the fuel tank, you can easily reach the pressure check points for the main hydraulic system, steering circuit and pilot control, all grouped together for time and cost reduction whilst improving efficiency, durability and the performance of your B90B.



PROTECTED BATTERY

The battery is both well protected and easy to reach for regular checks, in the box located on the right side, underneath the cab.

By removing one panel it is simple to access both the battery and the master switch.



Proactive maintenance assistance to improve machine durability, increase performance and reduce operating costs.

B90B COMFOR



SPACE CAB

The features and customer advantages of the B90B cab are so many that they cannot be summarised in a single sentence. "Space Cab" best describes it as it is incredibly roomy, with ample glass area to assure all-round cinemascopic visibility. Controls are ergonomically positioned, easy to reach and to read. Side windows can be fully or partially opened for good ventilation whilst, for the most severe climatic conditions, optional air conditioning is available. From his adjustable seat, the operator has his "world" under complete and comfortable control. For operator safety, the cab has an integral **ROPS** and **FOPS** structure and can be supplied with an optional electronic engine immobiliser.

T AND SAFETY



P.C.C. (PILOT COMMAND CONTROLS)*

Backhoe Pilot Command Controls, like those used on the latest generation excavators, are available on the B90B to provide operators with an extremely comfortable working environment. They guarantee a personalised working position, as manipulators may be moved and adjusted longitudinally and laterally. In addition, two tiltable and vertically adjustable wrist rests offer perfect support to operate joysticks with surgical precision. To suit operator requirements, command can be switched between backhoe and excavator pattern on demand, whilst the pilot control can be quickly disabled for safety reasons.

* In alternative simple and effective mechanical controls are available



INSTRUMENT PANEL

The B90B is equipped with a completely new, elegant car-style instrument panel which groups, on the cab right-hand side, the ignition key, the function buttons, high visibility analogic gauges, which monitor engine coolant temperature, engine r.p.m. and fuel level. In addition, there is a complete set of warning and signal lights, allowing the operator to constantly monitor the main machine parameters.

An elegant and practical instrument panel designed by New Holland engineers to help operators to perform better and more easily, in the most comfortable and productive way.

A cab designed for maximum operator comfort and safety thus allowing him to fully concentrate on the job for higher productivity and for a quick return on investment.

BOOB SPECIFICATIONS



ENGINE TIER 3A

Maximum power (ISO 14396/ECE R 120)72 kW/97 hp
 Rated engine speed2200 rpm
 Make and modeCNH 445TA/ML5
 TypeDiesel, 4 stoke, Direct injection,
 Turbo, Aftercooler

Displacement4.5 l
 Number of cylinders4
 Bore x stroke104 x 132 mm
 Maximum torque at 1250 rpm40 daNm

**Deceleration button: returns engine to minimum rpm when activated.
 -23°C outside temperature start as standard equipment**

The engine complies with 97/68/EC standards TIER 3A



ELECTRICAL SYSTEM

Voltage12 V
 Alternator90 A
 Starter motor2.7 kW
 Standard maintenance-free battery1
 Capacity95 Ah



HYDRAULIC SYSTEM

Load sensing, closed centre hydraulic system to maximise power exploitation and outstanding digging performance, top lifting capacity and fast loading cycle

Pumps2 gear type
 Total maximum flow160 l/min
 Max working pressure210 bar

BACKHOE CONTROL

Choice of:

Mechanical Controls to provide simple and precise movements
Pilot “Command Controls” to assure effortless and precise movements with extremely comfortable working conditions.

Pilot Command Controls and wrist rests are fully adjustable to guarantee the most ergonomic operator position for maximum productivity. For safety, Pilot Controls can be switched-off.

LOADER CONTROL

Multifunction lever with a new handle which includes proportional control for auxiliary hydraulic function (i.e. 4 in 1 bucket) and transmission disconnect button to maximise productivity and efficiency of front loader



CAB AND CONTROLS

High Space cab designed with the operator in mind to offer spacious and ergonomic environment and outstanding cinemascop, all-round visibility. Operator comfort is assured thanks to fully adjustable seat, mechanical or air suspension type and - fully or partially - opening side windows for good through-flow ventilation. New instrument panel to provide perfect visibility and control of all major machine parameters.



TRANSMISSION

Choice between:

Synchronised 4 x 4 Power Shuttle transmission to ensure forward & reverse quick and smooth shifting, resulting in high operator comfort. Torque converter stall ratio2.34:1

Forward speeds

	km/h
1.....	6.3
2.....	10.2
3.....	21.8
4.....	38.9

Reverse speeds

	km/h
1.....	7.6
2.....	12.3
3.....	26.2
4.....	46.4



BRAKES

Service brakesoil bath disc brakes, 4 per side on rear axle, mechanically operated by independent right and left pedals, which may be mechanically locked together. A three position switch in the cab, allows the operator to select:

- rear wheel drive brakes
- all wheel drive brakes
- rear wheel drive, all wheel brakes

Parking brakecaliper disc brake on transmission output shaft.



STEERING SYSTEM

TypeORBITROL with priority valve on one gear pump of the hydraulic system

Turning radius*:

Outside tyres4400 mm
 Bucket corner5700 mm

* Tyre size may effect turning radius.



TYRES

Front	Rear
12.5 - 18	18.4 - 26
320/80 - R 18	480/80 - R 26
12.5 - 18	16.9 - 28



CAPACITIES

	Litres
Fuel tank.....	125
Hydraulic tank.....	40
Hydraulic system.....	118
Engine cooling system.....	24
Engine oil.....	14
Transmission oil:	
Power Shuttle.....	18

STANDARD EQUIPMENT

- 12V power socket
- 2+2 front and rear working lights
- 2-4 wheel drive mode selector
- 40km/h travel speeds
- Adjustable opening windows
- All tinted glass
- Alternator 90A
- Backup alarm
- CNH Tier 3A diesel engine
- Free maintenance battery, 95 Ah
- Front and rear windshield wipers
- Front attachment with automatic return to dig
- Front counterweight
- Fuel filter
- Gauges for:
 - Engine coolant temperature
 - Engine rpm
 - Fuel level
- Ground line fuel fill with 125 litre capacity
- Hand throttle lever control
- Horn
- Load sensing, closed centre hydraulic system
- Multidisc oil bath brakes
- Powershuttle 4+4 transmission
- Rear axle with differential lock
- Road travel lights
- ROPS/FOPS cab with heating system
- Side mirrors
- Side shift
- Stabilisers control
- Transmission disconnect button

OPTIONS

- 20km/h travel speed
- Additional working lights
- Air conditioning
- Anti-theft device
- Backhoe buckets
- Backhoe quick coupler
- Biological hydraulic oil
- Cyclonic air pre-filter
- Dual batteries
- Front wheel fenders
- Hammer circuit
- Heavier counterweight
- Industrial or agricultural tyres
- Loader buckets
- Loader lock-out valves
- Loader quick coupler
- Mechanical or air suspension seat with belt
- Mechanical or pilot control
- Object handling kit with backhoe lifting hook and safety valves
- Road homologation
- Rotating beacon
- Stabiliser pads
- Standard or HED dipperstick
- Tool box

B90B

DIMENSIONS

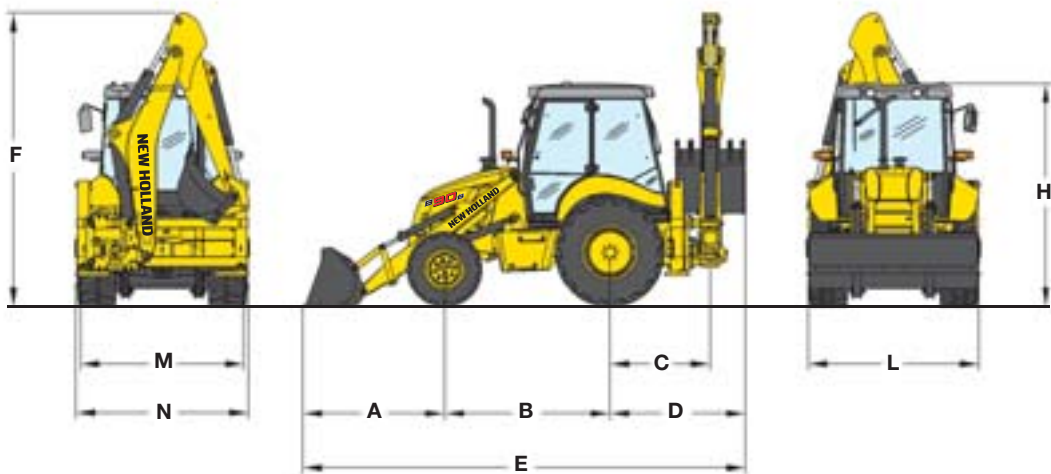

OVERALL DIMENSIONS

A Ground distance over front axle	mm	1870
B Wheelbase	mm	2175
C Pivot distance over rear axle	mm	1320
D Max distance over rear axle (with 915mm backhoe bucket)	mm	1780
E Overall length	mm	5825
F Height to top of boom	mm	3875
G Back ramp angle	°	23°
H Cab height	mm	2940
L Loader bucket width	mm	2250
M Stabiliser width	mm	2250
N Overall width	mm	2325

OPERATING WEIGHT

		STD DIPPER	HED DIPPER
Standard Bucket 1 m ³	kg	7480	7710
4x1 bucket 1 m ³	kg	7810	8040
6x1 bucket 1 m ³	kg	7970	8200

LOADER BUCKET

		STANDARD BUCKET	STANDARD BUCKET W/FORKS	4x1 BUCKET	6x1 BUCKET
Sae Capacity	m ³	1.00	1.00	1.00	1.00
Weight	kg	410	570	740	900
Width	mm	2250	2250	2250	2250

BACKHOE BUCKET

Sae Capacity	m ³	0.08	0.14	0.20	0.26	0.32
Weight	kg	110	132	150	172	193
Width	mm	305	460	610	760	915



B90B

WORKING RANGE

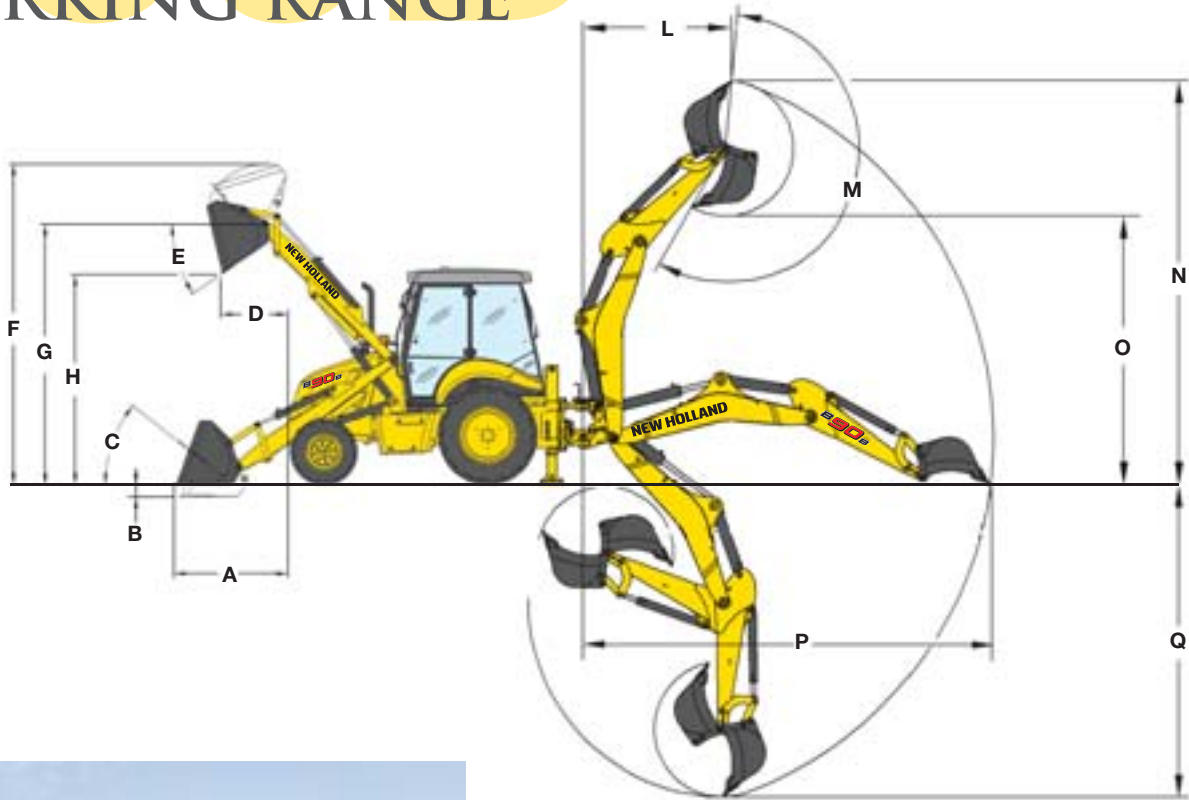

LOADER SPECIFICATIONS

A Reach at ground level	mm	1500
B Digging depth	mm	75
C Bucket roll back angle on ground	°	40
D Reach at full height	mm	785
E Bucket dump angle at full height	°	45
F Maximum operating height	mm	4330
G Hinge pin height	mm	3500
H Dump height	mm	2780

Maximum loader breakout force	daN	6900
Lifting capacity to maximum height	kg	3550

BACKHOE BREAKOUT FORCE

Bucket	daN	6400
Dipper breakout force (Std Dipper/HED retracted)	daN	4620
Dipper breakout force (HED extended)	daN	3200

BACKHOE SPECIFICATIONS		B90B		B90BLR	
		STD DIPPER HED RETRACTED	HED EXTENDED	STD DIPPER HED RETRACTED	HED EXTENDED
L Digging reach at max height	mm	2150	3060	2330	3190
M Bucket rotation	°	204	204	204	204
N Digging height	mm	5650	6290	5650	6305
O Dumping height	mm	3820	4550	3930	4585
P Digging reach at ground level	mm	5660	6680	5870	6815
Q Digging depth	mm	4450	5570	4710	5750

Machine equipped with: front tires 12.5/18, rear tires 18.4-26; base counterweight; standard bucket 1 m³.

NEW HOLLAND. THE POWER OF A GLOBAL BRAND

New Holland is a global brand with a key position in the Construction Equipment business. It supplies a complete range of 13 product lines and 80 basic models split into Compact line and Heavy line. It operates in all the main markets, such as Europe, North and Latin America, Africa, Asia and Middle East with the same technology and under the same logo and brand. It manufactures durable, safe and productive machines aimed at supporting customers in developing their own business. Dealers are company partners. They play an important role to support the brand in their territories through intense professional relationship with Customers. New Holland is reinforced by its global alliance with Kobelco: world leader in hydraulic excavator technology.



AT YOUR OWN DEALERSHIP

The information contained in this brochure is intended to be a general nature only. The NEW HOLLAND KOBELCO CONSTRUCTION MACHINERY S.p.A. company may at any time and from time to time, for technical or other necessary reasons, modify any of the details or specifications of the product described in this brochure. Illustrations do not necessarily show products in standard conditions. The dimensions, weights and capacities shown herein, as well as any conversion data used, are approximate only and are subject to variations within normal manufacturing techniques.

Published by NEW HOLLAND KOBELCO CONSTRUCTION MACHINERY S.p.A.
Printed in Italy - LEADER Firenze - Cod. 30 454GB - Printed 04/09

Printed on recycled paper
CoC-FSC 000010 CQ Mixed sources



ELEMENTAL
CHLORINE
FREE
GUARANTEED

FIAT
GROUP



BUILT AROUND YOU



www.newholland.com