



NEW HOLLAND

E195_B

NEW HOLLAND KOBELCO



NET FLYWHEEL POWER	93 kW - 125 hp
MAX OPERATING WEIGHT	20 600 kg
BUCKET CAPACITY	0.53 - 1.30 m ³



NEW HOLLAND

CONSTRUCTION

BUILT AROUND YOU

E195B* THE PE

TOP EFFICIENCY

Productivity (m³/l) + 5%

- **BREAK-OUT FORCE**
bucket 14700 daN + 5%
dipper 13700 daN + 5%
- **LIFTING CAPACITY +7%**
- **POWERFUL TRAVEL**
drawbar pull + 12 %



C.P.B. (Continuous Power Boost)

Continuous Power Boost is a feature of excellence of the E195B. Continuous Power Boost means that, if the operator is facing a very tough application, he can select this function (hydraulic pressure raises to 37.8 Mpa) **with no time limit**. Continuous Power Boost allows him to work without problems in job-site productivity and machine reliability. **A unique feature only offered by New Holland.**

* A product of the global alliance between New Holland and KOBELCO

PERFORMANCE

SUPERIOR & SAFE DYNAMIC STABILITY

The whole structure of E195B has been redesigned, to guarantee a perfect match with its higher performances, by improving position of centre of gravity, by optimising stresses distribution and by adopting higher quality steel plates. To eliminate bumps and shocks to the whole structure when the pistons reach their stroke end, cylinders have been equipped with automatic recovery and cushioning systems. In addition the undercarriage of EL version is now **9% longer**, thus effectively contributing to increased stability. **All this adds up to guarantee an excellent and safe machine with dynamic stability** when working in any kind of job and on all types of ground. This superb stability enhances the E195B **outstanding lifting capacity, increased by 7%.** **New Holland E195B features a Superior Breakout Force of 14700 daN or + 5%** which can be fully exploited, thanks to the weight strategically distributed in its structure, without unpleasant jumping effects.

- NEW larger displacement Environmentally Friendly Engine
- NEW generation hydraulic pumps
 - NEW hydraulic system
 - NEW longer undercarriage
- NEW flow & pressure set-up system
 - NEW operator compartment



E195B THE PO



RESPECTING THE ENVIRONMENT

The E195B is compliant with European Directives concerning electromagnetic compatibility and noise level. The emissions of the new Tier 3A CNH engine have been dramatically reduced and are, as shown below, much lower than standard requirements.

CO: 0.87, HC: 0.13, NOx: 3.72, Particulate: 0.19 (*)

In addition, this engine can use normal diesel, with up to **20% of Biodiesel added...**
...a real Environmentally Friendly machine.

(*) all data are expressed in g/kWh

POWER OF CONTROL



NEW CNH ENGINE

The new CNH, 4 cylinders, 4.5 litres mechanical engine develops a power of 93 kW at 2200 rpm and a higher torque of 525 Nm at lower rpm... **an extremely flexible and responsive power plant.**

A larger displacement engine guarantees:

- Higher torque for higher productivity
- Longer lifespan
- Higher reliability



NEW HYDRAULIC PUMPS

The E195B is equipped with two new generation low noise hydraulic pumps able to supply a high flow: **state-of-the-art pumps, easy to control, prompt to react to all requirements and extremely noiseless.**

ELECTRONIC CONTROL

Sensors are located in the pilot lines, sending signals to the on-board computer that are proportional to the manipulator's strokes. These signals are managed together with engine r.p.m. to tune the quantity of hydraulic oil requested **to guarantee extremely smooth and precise controls, excellent stability and steady speed during simultaneous operations.**



LOW EFFORT & PRECISE JOYSTICKS

All machine movements can be smoothly controlled by **low effort joysticks...** a real, effective **Control of Power** allowing longer work times with less fatigue. The joystick illustrated is supplied as an option, together with rotating bucket circuit.

E195B ADVANC



NEW HYDRAULIC SYSTEM

EFFICIENCY AND CONTROLLABILITY

To obtain a Hydraulic System which is much more efficient, controllable, fast and powerful, and which consumes less fuel than previously, New Holland engineers have been working not only on pumps but also on a completely redesigned and refined Control Valve adding a second arm spool, increased swing output torque and new working mode selection functions. Movement speed has been increased and machine controllability improved, especially on operations that require combined movements. This outstanding characteristic is further enhanced by the new **H.A.O.A. Control**.

H.A.O.A. (Hydrotronic Active Operation Aid)

Hydrotronic Active Operation Aid is the most effective available combination of an extremely advanced electronic technology that provides a “just in time” comprehensive control of all machine functions, and a deeply refined and sophisticated hydraulic system. H.A.O.A. continuously optimises hydraulic output according to operator and job demand, providing the best machine controllability, productivity, operator comfort and fuel savings.

ED HYDRAULIC SYSTEM



A.E.P. - (Advanced Electronic Processor)

A.E.P. is a new Electronic Processor that interacts with the operator for selecting and monitoring all main working parameters, maintenance notifications, self diagnosis and operating data storage.

All this information is displayed in the new monitor, which features a larger back-lit, easier to read digital display and analogic gauges.

Simply select the requested working mode and A.E.P. pre-sets the hydraulic system to accomplish the job in the easiest and most productive way:

- **S mode** for normal working operations
- **H mode** when maximum power is required

Two additional modes are available for special applications and to operate tools like breakers and crushers:

- **A mode** adjusts the attachment circuit for tools which require two way flow.

A dedicated switch on the dashboard, enables the operator to select two pumps oil flow

- **B mode** for attachments featuring one way flow only

Both in A and B working modes the operator, by using the buttons on the monitor, may adjust the flow by 10 l/min steps and the pressure by 10 bars steps to perfectly match the parameters of the attachment being used.

In addition, the operator can save to memory 9 combinations of flow and pressure in both A and B working modes, for a total of 18 combinations.

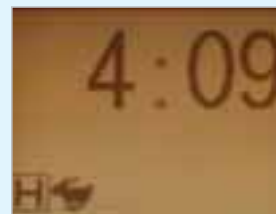
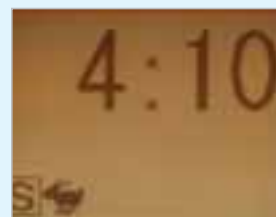

D.O.C. (Dipperstick Optimised Control)

The newly redesigned Control Valve features a second spool dedicated to dipperstick operation. The movement “dipper out” is now achieved with a double flow, i.e., using the flow of the two pumps. The “dipper in” movement is even faster because of the double pump flow combined with the “Conflux”, or recirculation of unused oil which is diverted from return to tank.

A perfect combination of speed, efficiency, precision and increased production.

OBJECT HANDLING KIT

European Standards state rules of thumb that do not allow free interpretation to each European Country. In case of object handling operations, an excavator can be used **only if certified by manufacturer** that it is equipped with all safety devices required by European Standards EN 474-5 : 1996.

New Holland, confirming its commitment to grant high performances in an extremely safe environment, offers its customers the **optional Object Handling Kit** for maximum operator confidence.

E195B HIGH RE

TOP DESIGN & PRODU

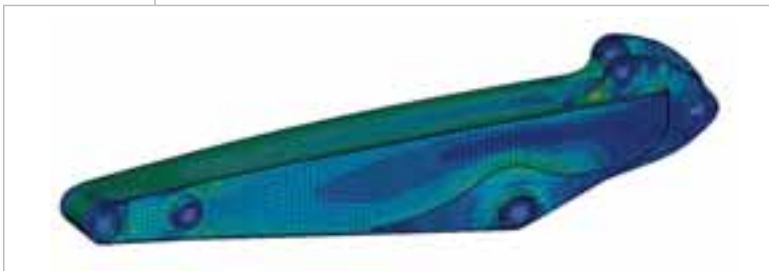
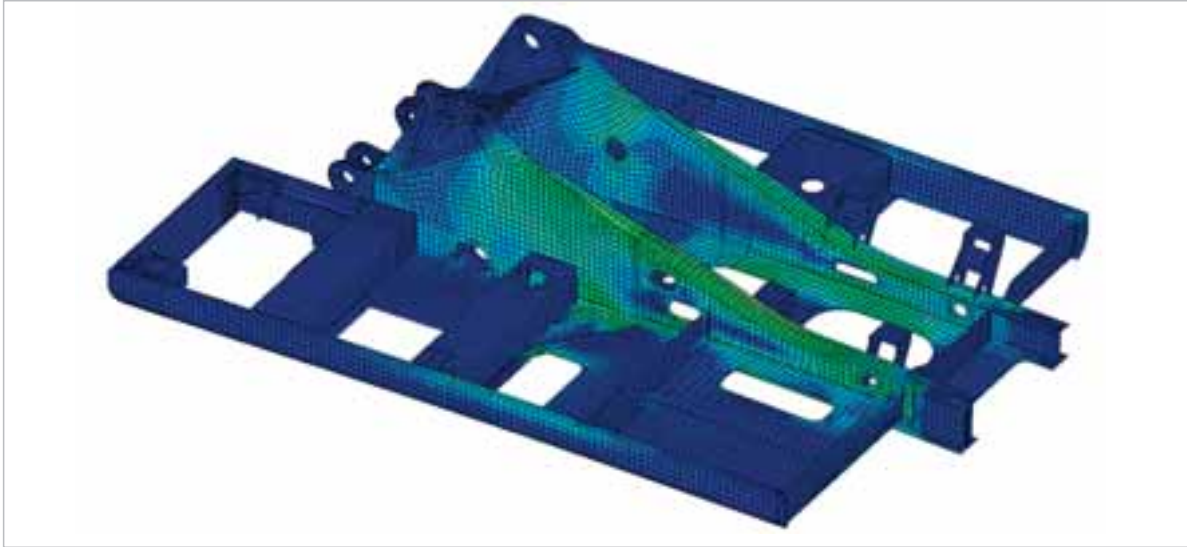

Booms and Arms have been redesigned using advanced CAD (Computer Aided Design) and FEM (Finite Elements Methodology) Systems to get higher strength **only** in those areas where stresses are concentrated.

These sophisticated design methodologies are combined with the most advanced production technologies, providing high tensile steel plates that are cut, assembled and welded at the New Holland plant, which since many years holds the prestigious **"Vision 2000" Quality Certification**.

The same innovative guidelines, to achieve **Heavy Duty** maximum strength together with outstanding torsional and flexional resistance, are applied in design and manufacture of upper structure and the undercarriage.



T NEW BOOM & ARM

To further extend Arms durability even in rocky applications, New holland offers as optional a robust Arm protection.

RELIABILITY & DURABILITY PROTECTION TECHNOLOGIES



NEW LONG UNDERCARRIAGE FOR BOTH VERSIONS

The length of the two versions EL & LC have been increased from 3370 to 3660 mm for enhanced durability, reliability, stability and performance, together with improved flotation in very wet ground and increased operator comfort.

A TRACK GUIDE

A central mounted track guide is supplied as standard equipment on both track frames. If machine has to work and move in very uneven and rocky terrain, customers may choose the **optional 4 additional track guides** which are mounted, two per track frame, front and rear of the central ones. They contribute to keeping the chains on the rollers and protecting them at the same time, resulting in **extended durability, maximum efficiency and safety.**

LENGTH INCREASED BY + 6% ⇒ HIGH STABILITY

BUCKET LINKAGE WITH DOUBLE BUSHING

The arm/bucket long-life internal bushing now has extra protection from wear due to contact with the bucket linkage, thanks to new additional external bushings made from anti-wear steel material. When the radial surface is worn this new bushing can be easily changed, thus increasing pin and bushing durability while reducing ownership costs. E195B uses same buckets of previous model and E215B.



E195B OPERATOR



NEW ONE-HAND WINDSCREEN OPENING

One-touch lock release simplifies opening and closing the front window, while a new mechanism makes it lighter.



INSTRUMENT LAYOUT

In-cab switches and controls have been moved to the right-hand side in an easy to reach and more ergonomic position, thus improving operator comfort and convenience.



NEW A. E. P. MONITOR

The newly designed A.E.P. Monitor, features analogical gauges which provide one sight advice, regardless of the operating environment.

The digital Display Screen has been enlarged to further enhance visibility. Maintenance information is clearly displayed and the self-diagnostic function provides an early warning detection of malfunctions.

Details of any previous breakdown or malfunction are also stored.

R SAFETY AND COMFORT

NEW EVO CAB EVOLUTION IN COMFORT AND SAFETY

The interior of the cab has been completely re-designed to maximise operator comfort and to enable optimum operator performance. All switches and controls are now ergonomically positioned on the right side, easy to find and to reach. Enlarged side windows enhance the panoramic view.

The radio and the new, more powerful and effective automatic air-conditioning system are standard equipment, creating an agreeable working atmosphere regardless of external weather conditions. At the same time, new interior design and materials create an elegant feeling.

Six silicon liquid filled viscous dampers minimise vibrations.

The new, reinforced structure of the cab complies to ROPS and FOPS standards. Together with the optional front guard it's effectively contributing to operator safety.



NEW COMFORTABLE SEAT

New comfortable contoured seat which can be adjusted in all directions and back and forth, together with or independently of side consoles.

The armrests, integrated on side consoles, can be lifted/lowered into four different positions and inclined, enabling the operator to set the correct position for maximum convenience and comfort.



UNIQUE REAR CAMERA WITH “DEDICATED” IN CAB SCREEN

This is a very special option, enhancing active safety for both the operator and others on the job site. The “**dedicated screen**” is mounted inside the cab and is **unique to New Holland**. It allows the operator, whilst working, to simultaneously control both the job going on behind his machine and the machine's functional parameters, thanks to the **A.E.P.** display, which operates constantly. A really unique and outstanding feature in terms of **safety and comfort**.





E195B EASY MAIN

DESIGNED TO EFFECTIVELY CUT OPERATING COSTS

T CLEAN AND ACCESSIBLE LAYOUT

The new machine layout has been designed to make inspections, maintenance and servicing much easier and less time-consuming. The engine oil filter, the fuel filter and the water separator are remote mounted and easy to reach from ground level. Both the fuel filter and the water separator, which removes contaminants and water, have an important function for engine performance and durability. Cooling components (radiator, hydraulic oil cooler and intercooler) are now mounted in parallel, which means increased cooling efficiency for higher component reliability whilst being easier to check and clean.



The simplified layout of all vital components of the New Holland E195B under both the right and the left side panels makes maintenance much easier, less time consuming and less costly, and provides much better access for servicing. There is plenty of room in all compartments and most components are positioned in such a way to enable easy access from ground level. **An elegant and modern design added to state-of-the-art technology.**



CENTRALISED GREASING

Maintenance procedures are also improved thanks to new grouped and centralised greasing points, which allow all boom wear points to be easily greased from ground level, after every 500 hours-long lasting intervals! On request, the E195B can be equipped with an **“Automatic Centralised Greasing System”** to supply all wear points of the machine with the right quantity of grease at the right time. A winning tool to **simultaneously reduce maintenance procedures and costs while improving machine reliability and durability.**

MAINTENANCE & SERVICEABILITY

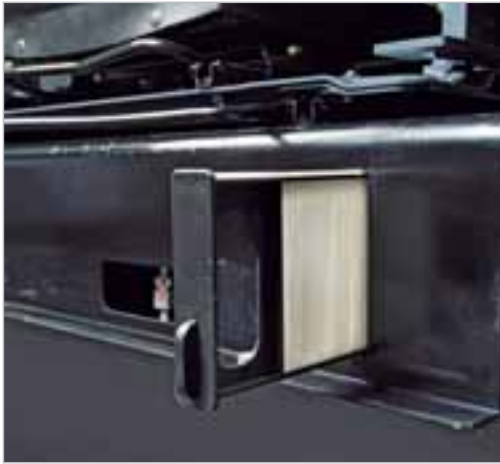

INSIDE CAB MAINTENANCE

■ Airconditioning filter, positioned under the seat, can be easily removed without tools and from ground level, for easy cleaning.



■ Detachable two-piece floor mat with handles for easy removal. A floor drain is located under the mat to facilitate inside cab cleaning.



FUSES

The fuses are inside the cab, protected from dust and water as well as easy to reach and control.



TOOL BOX

The tool box has been completely redesigned with a side-opening panel. It stores a new electric immersion type fuel pump, with automatic stop and alarm when the tank is full. The repositioning of the batteries (under the cooling components) and of the fuses (inside the cab) makes room in the compartment behind the cab for an additional wide and useful tool box.

E195B

SPECIFICATIONS



ENGINE TIER 3A

Net flywheel power (ISO 14396/ECE R 120)93 kW/125 hp
 Governed2200 rpm
 Make and modelCNH 445TA/MLF
 TypeDiesel 4-stroke, direct injection, turbocharged and intercooler
 Displacement4.5 l
 Number of cylinders4
 Bore x stroke104 x 132 mm
 Maximum torque at 1250 rpm525 Nm

Remote engine oil filter for easy replacement

Electronic engine rpm control, dial type

Auto-Idling selector returns engine to minimum rpm when all controls are in neutral position

-25°C outside temperature start as standard equipment

The engine complies with 97/68/EC standards TIER 3A



ELECTRICAL SYSTEM

Voltage24 V
 Alternator70 A
 Starter motor4 kW
 Standard maintenance-free batteries2
 Capacity100 Ah



HYDRAULIC SYSTEM

Redesigned Main Control Valve, with added 2nd dipper spool and new Fail Safe Functions;

H.A.O.A. (Hydrotronic Active Operation Aid) to get the best hydraulic output according to operator/ application demand;

E.S.S.C. (Engine Speed Sensing Control) device, for total installed hydraulic power exploitation;

D.O.C. (Dipper Optimised Control) thanks to the 2nd dedicated spool in the Control Valve and to the Conflux system;

C.P.B. (Continuous Power Boost) to allow the operator to use extra power when and how long it is needed;

A.E.P. (Advanced Electronic Processor) interacting with the operator for selecting and monitoring main working parameters, maintenance programmes, self diagnosis and operating data storage thanks to the new monitor with a larger digital display and analogical gauges;

Two working modes:

- **S** = for normal digging operation;
- **H** = when maximum power is required;

Two Attachments modes:

- **A** = for attachments which require double pump flow;
- **B** = for attachments, such as breaker, featuring one way flow only.

Standard double pump flow device and Diverter Valve automatically actuated while selecting A;

Pipe pressure discharge push button to facilitate tooling changeover without piping oil leakage;

Super Fine hydraulic filter (8 micron) to grant perfect oil filtration, contributing to increase oil change interval

Main pumps:

Two variable delivery pumps with electronic delivery adjustment. Pumps automatically revert to zero delivery with controls in neutral.

Maximum delivery2 x 176 l/min

Piloting circuit gear type pump

Maximum delivery22 l/min

Maximum operating pressure:

- Equipment/travel34.3 MPa
 - Swing30.0 MPa
 - Power Boost37.8 MPa
- Hydraulic cylindersdouble effect
- Lift (2) - bore x stroke110 x 1150 mm
 - Dipperstick (1) - bore x stroke130 x 1290 mm
 - Bucket (1) - bore x stroke110 x 1105 mm
 - Positioning (only triple articulation) bore x stroke135 x 1010 mm

Independent hammer/positioning control



TRANSMISSION

Typehydrostatic, two-speeds
 Travel motors2, axial piston type, double displacement
 Brakesoil bath discs type, automatically applied and hydraulically released

Final driveoil bath, planetary reduction
 Gradeability (continuous)70% (35°)

Travel speeds:

- Lowfrom 0 to 3.0 km/h
- Highfrom 0 to 5.0 km/h

Drawbar pull224 kN

Automatic DownShift device: to move travel motors to maximum displacement position with selector on "high speed" position when greater traction is required.



SWING

Swing motoraxial piston type
 Swing brakeoil bath discs type, automatically applied and hydraulically released

Final driveoil bath, planetary reduction
 Swing ringgrease bath type
 Swing speed11.5 rpm



CAB AND CONTROLS

Sound suppressed cab with modern design, integrated ROPS and standard FOPS, tinted safety glass, insertable front window, transparent cab roof. Standard automatic air conditioning and radio.

Controlspiloted
 Two cross path manipulators actuate all equipment movements and upperstructure swing.

Two pedals with hand levers control all track movements, counter-rotation included.

A safety lever completely neutralizes the piloting circuit



UNDERCARRIAGE

X-frame undercarriage design

Reinforced track chain with sealed bushings.

	E195BEL	E195BLC
Track rollers (each side)	8	8
Carrier rollers (each side)	2	2
Length of track on ground (mm)	3660	3660
Gauge (mm)	1990	2200
Shoes (mm)	500-600-700	600-700
	800	800-900



CAPACITIES

	litres
Lube oil	14.5
Coolant	18.0
Fuel tank	260.0
Hydraulic system	180.0

STANDARD EQUIPMENT

- Automatic Air Conditioning System
- Automatic fuel electrical pump
- Auto-Idling device
- Batteries, maintenance free
- Centralised boom lubrication
- Double pumps flow
- Engine rpm electronic control
- EVO cab, FOPS and ROPS in compliance with Machine Directive
- Foot pedal with lever travel control
- Front seal hydraulic piping and connections
- Grease bath swing ring
- H.A.O.A. (Hydrotronic Active Operation Aid)
- HD chains
- Horn
- Hydraulically suspended cab with transparent roof
- Main control valve with antidrift valves
- Mechanical cushioned seat
- Multi-function monitor
- One-piece boom or triple articulation
- Power Boost device
- Radio set
- Rear view mirror on counterweight
- Swing and travel motors with automatic disc type brakes
- Tier-3A emissioned diesel engine
- Tool kit
- Two-speed intermittent operation windshield wiper
- Two travel speeds with Automatic DownShift device
- Two working lights on boom and one on upperstructure

OPTIONS

- 2200 mm Dipperstick
- 2600 mm Dipperstick
- 3100 mm Dipperstick
- Antitheft device
- Arm protection
- Biological hydraulic oil
- Cab additional lights and rain protection
- Customer colour
- Front Guard protection for cab (FOG in compliance with Machine Directive)
- Hammer and crusher circuit
- Hydraulic quick coupler provision
- Lower frame guard
- Multi-purpose, rock and heavy duty buckets with boom/bucket adjustment device
- Object Handling kit
- Pneumatic cushioned and heated seat
- Rear view camera with dedicated display
- Rotating bucket circuit
- Shoes:
 - EL version 500 - 600 - 700 mm
 - LC version 600 - 700 - 800 - 900 mm
- Track guide

Note: standard and optional equipment may vary by country. Consult your NEW HOLLAND KOBELCO dealer for specific.

ONE-PIECE BOOM

TRIPLE ARTICULATION

BUCKETS			E195B EL			E195B LC			E195B EL			E195B LC		
Width (mm)	Capacity (m ³) SAE J296 (ISO 7451)	Weight (Kg)	Dipper mm			Dipper mm			Dipper mm			Dipper mm		
			2200	2600	3100	2200	2600	3100	2200	2600	3100	2200	2600	3100
750	0.52	505	■	■	■	■	■	■	■	■	■	■	■	■
850	0.63	540	■	■	■	■	■	■	■	■	■	■	■	■
1000	0.79	635	■	■	■	■	■	■	■	■	■	■	■	■
1200	1.00	650	■	■	■	■	■	■	■	■	■	■	■	■
1300	1.10	700	■	■	■	■	■	■	■	■	■	■	■	■

- General digging work (specific weight of material < 1.8 t/m³)
- Slightly heavy digging work (specific weight of material < 1,5 t/m³)
- Loading work (specific weight of material < 1,2 t/m³)

E195B

ONE-PIECE BOOM

DIMENSIONS (mm) - OPERATING WEIGHT

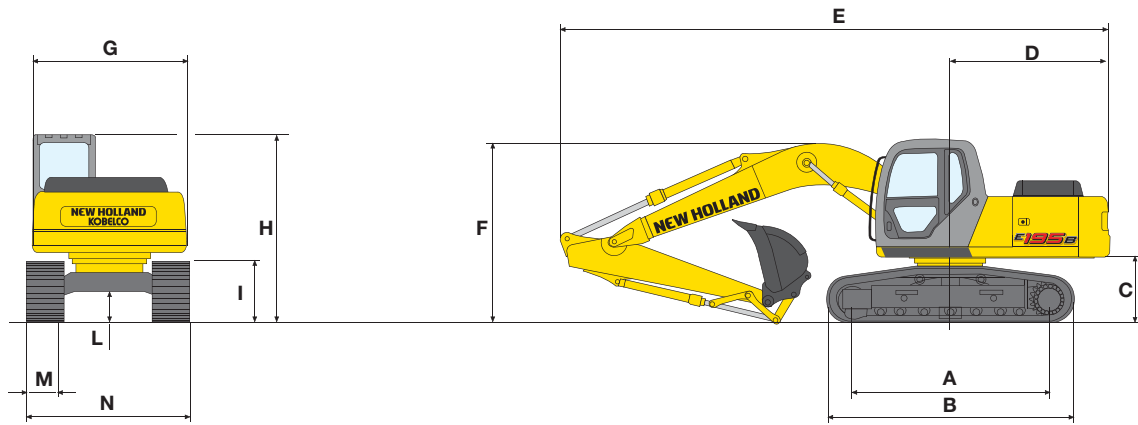

VERSIONS	A	B	C	D	E(*)	F(*)	G	H	I	L
					(1) 8880	(1) 3030				
E195BEL	3660	4450	1035	2620	(2) 8795	(2) 2930	2500	3085	950	470
					(3) 8785	(3) 3010				
					(1) 8880	(1) 3030				
E195BLC	3660	4450	1035	2620	(2) 8795	(2) 2930	2500	3085	950	470
					(3) 8785	(3) 3010				

(*) Dipperstick: (1) 2200 mm, (2) 2600 mm, (3) 3100 mm

		E195BEL			E195BLC			
M - Shoe width	mm	500	600	700	600	700	800	900
N - maximum width	mm	2490	2590	2690	2800	2900	3000	3100
Operating weight (*)	kg	18600	18850	19100	19150	19400	19650	19900
Ground pressure	bar	0.50	0.42	0.37	0.42	0.37	0.32	0.29

(*) With 3100 mm Dipperstick and 1.3 m³ bucket

DIGGING PERFORMANCE

ONE-PIECE BOOM = 5200 mm

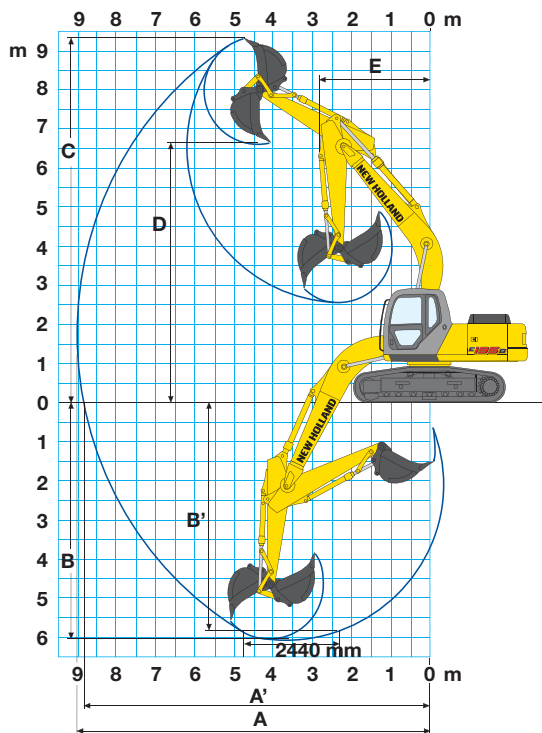

DIPPERSTICK	mm	2200	2600	3100
A	mm	8680	9085	9615
A'	mm	8490	8900	9440
B	mm	5720	6120	6620
B'	mm	5450	5890	6440
C	mm	8790	9120	9590
D	mm	6510	6720	7095
E	mm	3060	2850	2890

BREAKOUT FORCE:

Bucket	daN	13200	13200	13200
Dipperstick	daN	12390	10500	9100

WITH POWER BOOST ON

Bucket	daN	14700	14700	14700
Dipperstick	daN	13750	11550	9750

TRIPLE ARTICULATION

DIMENSIONS (mm) - OPERATING WEIGHT

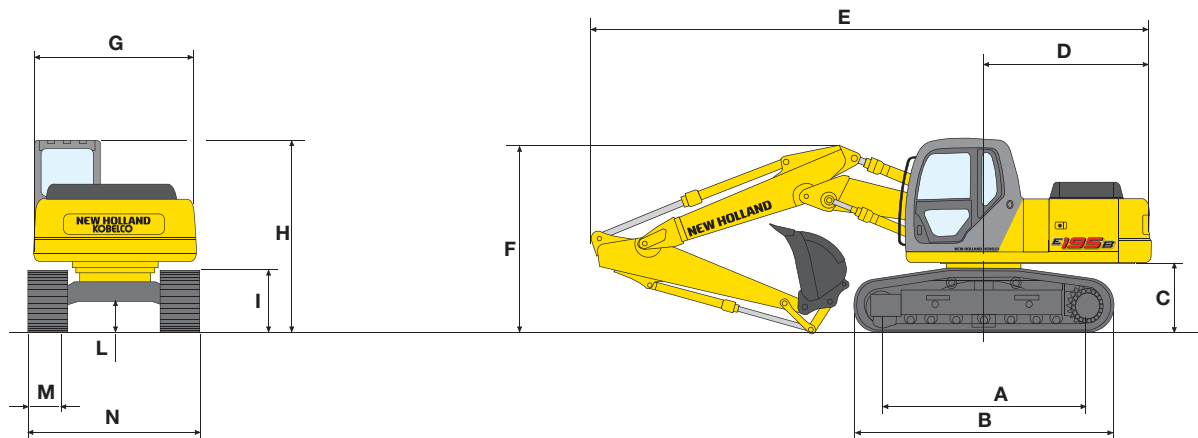

VERSIONS	A	B	C	D	E(*)	F(*)	G	H	I	L
					(1) 8725	(1) 3070				
E195BEL	3655	4450	1035	2620	(2) 8640	(2) 2975	2500	3085	950	470
					(3) 8625	(3) 3080				
					(1) 8725	(1) 3070				
E195BLC	3655	4450	1035	2620	(2) 8640	(2) 2975	2500	3085	950	470
					(3) 8625	(3) 3080				

(*) Dipperstick: (1) 2200 mm, (2) 2600 mm, (3) 3100 mm

		E195BEL			E195BLC			
M - Shoe width	mm	500	600	700	600	700	800	900
N - maximum width	mm	2490	2590	2690	2800	2900	3000	3100
Operating weight (*)	kg	19300	19550	19800	19850	20100	20350	20600
Ground pressure	bar	0.52	0.44	0.38	0.44	0.38	0.34	0.30

(*) With 3100 mm Dipperstick and 1.3 m³ bucket

DIGGING PERFORMANCE

TRIPLE ARTICULATION
max extension= 5045 mm
min extension= 3685 mm

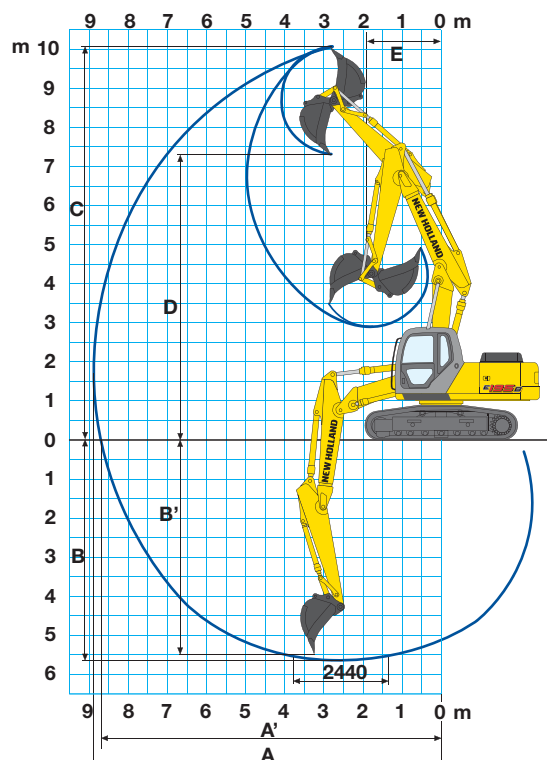

DIPPERSTICK	mm	2200	2600	3100
A	mm	8550	8650	9480
A'	mm	8350	8765	9305
B	mm	5305	5710	6230
B'	mm	5180	5600	6125
C	mm	9635	10010	10533
D	mm	6565	7265	7730
E	mm	2425	2215	2260

BREAKOUT FORCE:

	daN	13200	13200	13200
Bucket	daN	13200	13200	13200
Dipperstick	daN	12390	10500	9100

WITH POWER BOOST ON

	daN	14700	14700	14700
Bucket	daN	14700	14700	14700
Dipperstick	daN	13750	11550	9750

E195B LIFTING CAPACITY

2200 mm DIPPERSTICK

VALUES ARE EXPRESSED IN TONNES

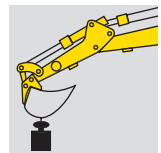

RADIUS OF LOAD

1.5 m		3.0 m		4.5 m		6.0 m		7.5 m		AT MAX. REACH		REACH m
FRONT	SIDE	FRONT	SIDE	FRONT	SIDE	FRONT	SIDE	FRONT	SIDE	FRONT	SIDE	

E195BEL ONE-PIECE BOOM

HEIGHT	1.5 m		3.0 m		4.5 m		6.0 m		7.5 m		AT MAX. REACH		REACH m
	FRONT	SIDE	FRONT	SIDE	FRONT	SIDE	FRONT	SIDE	FRONT	SIDE	FRONT	SIDE	
+7.5 m													
+6.0 m							4.3*	3.7			4.2*	3.5	6.1
+4.5 m					5.1*	4.8*	4.5*	3.6			4.2*	2.8	6.9
+3.0 m			9.6*	9.0*	6.3*	5.2	4.9*	3.4			4.4*	2.5	7.4
+1.5 m			9.8*	8.5	7.4*	4.8	5.5*	3.2			4.4*	2.4	7.5
0			11.1*	8.3	7.8*	4.6	5.8*	3.1			4.5	2.4	7.2
-1.5 m	9.8*	9.2*	11.0*	8.4	7.6*	4.5	5.6*	3.1			4.9*	2.7	6.7
-3.0 m	13.8*	12.9*	9.2*	8.6	6.6*	4.6					5.0*	3.4	5.7
-4.5 m			5.9*	5.5*							4.8*	4.5*	3.9

E195BEL TRIPLE ARTICULATION

HEIGHT	1.5 m		3.0 m		4.5 m		6.0 m		7.5 m		AT MAX. REACH		REACH m
	FRONT	SIDE	FRONT	SIDE	FRONT	SIDE	FRONT	SIDE	FRONT	SIDE	FRONT	SIDE	
+7.5 m					4.7*	4.4*					4.5*	4.2*	4.4
+6.0 m					5.1*	4.8*	4.2*	3.7			4.2*	3.7	5.9
+4.5 m			7.7*	7.2*	5.6*	5.2*	4.3*	3.6			3.9*	2.9	6.7
+3.0 m			11.2*	9.9	6.6*	5.3	4.7*	3.5			3.7*	2.6	7.1
+1.5 m			10.9*	8.8	7.9*	4.9	5.1*	3.3			4.0*	2.4	7.2
0			11.2*	8.5	7.8*	4.6	5.7*	3.1			4.3*	2.5	7.0
-1.5 m			9.0*	8.4	6.7*	4.5	4.9*	3.1			4.2*	2.7	6.5
-3.0 m			5.9*	5.5*	4.7*	4.4*					3.5*	3.3*	3.0
-4.5 m													

E195BLC ONE-PIECE BOOM

HEIGHT	1.5 m		3.0 m		4.5 m		6.0 m		7.5 m		AT MAX. REACH		REACH m
	FRONT	SIDE	FRONT	SIDE	FRONT	SIDE	FRONT	SIDE	FRONT	SIDE	FRONT	SIDE	
+7.5 m													
+6.0 m							4.3*	4.0*			4.2*	3.9*	6.1
+4.5 m					5.1*	4.8*	4.5*	4.0			4.2*	3.2	6.9
+3.0 m			9.6*	9.0*	6.3*	5.9*	4.9*	3.9			4.4*	2.8	7.4
+1.5 m			9.8*	9.2*	7.4*	5.5	5.7*	3.9			4.5	2.7	7.5
0			11.1*	9.8	7.8*	5.3	5.8*	3.5			4.6	2.7	7.2
-1.5 m	9.8*	9.2*	11.0*	9.8	7.6*	5.2	5.6*	3.5			4.9*	3.0	6.7
-3.0 m	13.8*	12.9*	9.2*	8.6*	6.6*	5.3					5.0*	3.9	5.7
-4.5 m			5.9*	5.5*							4.8*	4.5*	3.9

E195BLC TRIPLE ARTICULATION

HEIGHT	1.5 m		3.0 m		4.5 m		6.0 m		7.5 m		AT MAX. REACH		REACH m
	FRONT	SIDE	FRONT	SIDE	FRONT	SIDE	FRONT	SIDE	FRONT	SIDE	FRONT	SIDE	
+7.5 m					4.7*	4.4*					4.5*	4.2*	4.4
+6.0 m					5.1*	4.8*	4.2*	3.9*			4.2*	3.9*	5.9
+4.5 m			7.7*	7.2*	5.6*	5.2*	4.3*	4.0*			3.9*	3.3	6.7
+3.0 m			11.2*	10.5*	6.6*	6.0	4.7*	3.9			3.7*	2.9	7.1
+1.5 m			10.9*	10.2*	7.9*	5.6	5.1*	3.7			4.0*	2.7	7.2
0			11.2*	10.0	7.8*	5.3	5.7*	3.6			4.3*	2.8	7.0
-1.5 m			9.0*	8.4*	6.7*	5.2	4.9*	3.5			4.2*	3.1	6.5
-3.0 m			5.9*	5.5*	4.7*	4.4*					3.5*	3.3*	3.0
-4.5 m													

The table values refer to ISO 10567 for excavator equipped with bucket. The indicated load is no more than 87% of hydraulic system lift capacity or 75% of static tipping load. Values marked with an asterisk are limited by the hydraulic system.

LIFTING CAPACITY

2600 mm DIPPERSTICK

VALUES ARE EXPRESSED IN TONNES

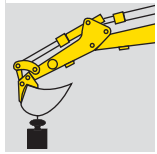

RADIUS OF LOAD

1.5 m		3.0 m		4.5 m		6.0 m		7.5 m		AT MAX. REACH		REACH m
FRONT	SIDE	FRONT	SIDE	FRONT	SIDE	FRONT	SIDE	FRONT	SIDE	FRONT	SIDE	

E195BEL ONE-PIECE BOOM

HEIGHT		1.5 m		3.0 m		4.5 m		6.0 m		7.5 m		AT MAX. REACH		REACH m
FRONT	SIDE	FRONT	SIDE	FRONT	SIDE	FRONT	SIDE	FRONT	SIDE	FRONT	SIDE	FRONT	SIDE	
+7.5 m												2.9 *	2.7 *	5.5
+6.0 m								3.9 *	3.6 *			2.7 *	2.5 *	6.7
+4.5 m								4.2 *	3.6			2.7 *	2.5	7.5
+3.0 m				8.6 *	8.0 *	5.8 *	5.3	4.7 *	3.4	4.1 *	2.4	2.9 *	2.2	7.8
+1.5 m				11.4 *	8.7 *	7.1 *	4.9	5.2 *	3.2	4.3 *	2.3	3.1 *	2.1	7.9
0				11.1 *	8.3	7.7 *	4.6	5.7 *	3.1	4.3	2.3	3.6 *	2.1	7.7
-1.5 m	8.5 *	7.9 *		11.4 *	8.3	7.7 *	4.5	5.7 *	3.0			4.5	2.4	7.2
-3.0 m	12.1 *	11.3 *		10.0 *	8.4	7.0 *	4.5	4.9 *	3.1			4.6 *	2.9	6.3
-4.5 m				7.1 *	6.6 *	4.9 *	4.6 *					4.6 *	4.3 *	4.7

E195BEL TRIPLE ARTICULATION

HEIGHT		1.5 m		3.0 m		4.5 m		6.0 m		7.5 m		AT MAX. REACH		REACH m
FRONT	SIDE	FRONT	SIDE	FRONT	SIDE	FRONT	SIDE	FRONT	SIDE	FRONT	SIDE	FRONT	SIDE	
+7.5 m						4.4 *	4.1 *					2.9 *	2.7 *	5.2
+6.0 m						4.8 *	4.5 *	4.0 *	3.7 *			2.7 *	2.5 *	6.5
+4.5 m						5.1 *	4.8 *	4.1 *	3.7			2.7 *	2.5 *	7.2
+3.0 m				10.4 *	9.7 *	7.2 *	5.4	4.4 *	3.5	3.4 *	2.4	2.8 *	2.3	7.6
+1.5 m				12.3 *	9.0	7.7 *	4.9	4.9 *	3.3	3.6 *	2.3	3.1 *	2.2	7.7
0	5.0 *	4.7 *		11.8 *	8.5	7.8 *	4.6	5.5 *	3.1	3.9 *	2.3	3.6 *	2.2	7.5
-1.5 m	8.7 *	8.1 *		9.8 *	8.2 *	7.1 *	4.4	5.1 *	3.0			3.9 *	2.4	7.0
-3.0 m				7.1 *	6.6 *	5.4 *	4.4	3.6 *	3.0			3.4 *	3.0	6.0
-4.5 m														

E195BLC ONE-PIECE BOOM

HEIGHT		1.5 m		3.0 m		4.5 m		6.0 m		7.5 m		AT MAX. REACH		REACH m
FRONT	SIDE	FRONT	SIDE	FRONT	SIDE	FRONT	SIDE	FRONT	SIDE	FRONT	SIDE	FRONT	SIDE	
+7.5 m												2.9 *	2.7 *	5.5
+6.0 m								3.9 *	3.6 *			2.7 *	2.5 *	6.7
+4.5 m								4.2 *	3.9 *			2.7 *	2.5 *	7.5
+3.0 m				8.6 *	8.0 *	5.8 *	5.4 *	4.7 *	3.9	4.1 *	2.7	2.9 *	2.5	7.8
+1.5 m				11.4 *	10.2	7.1 *	5.6	5.2 *	3.7	4.3 *	2.6	3.1 *	2.4	7.9
0				11.1 *	9.7	7.7 *	5.3	5.7 *	3.5	4.3	2.6	3.6 *	2.5	7.7
-1.5 m	8.5 *	7.9 *		11.4 *	9.7	7.7 *	5.2	5.7 *	3.4			4.5	2.7	7.2
-3.0 m	12.1 *	11.3 *		10.0 *	9.3 *	7.0 *	5.2	4.9 *	3.5			4.6 *	3.3	6.3
-4.5 m				7.1 *	6.6 *	4.9 *	4.6 *					4.6 *	4.3 *	4.7

E195BLC TRIPLE ARTICULATION

HEIGHT		1.5 m		3.0 m		4.5 m		6.0 m		7.5 m		AT MAX. REACH		REACH m
FRONT	SIDE	FRONT	SIDE	FRONT	SIDE	FRONT	SIDE	FRONT	SIDE	FRONT	SIDE	FRONT	SIDE	
+7.5 m						4.4 *	4.1 *					2.9 *	2.7 *	5.2
+6.0 m						4.8 *	4.5 *	4.0 *	3.7 *			2.7 *	2.5 *	6.5
+4.5 m						5.1 *	4.8 *	4.1 *	3.8 *			2.7 *	2.5 *	7.2
+3.0 m				10.4 *	9.7 *	6.1 *	5.7 *	4.4 *	3.9	3.4 *	2.7	2.8 *	2.6	7.6
+1.5 m				12.3 *	10.5	7.7 *	5.6	4.9 *	3.7	3.6 *	2.7	3.1 *	2.5	7.7
0	5.0 *	4.7 *		11.8 *	9.9	7.8 *	5.3	5.5 *	3.5	3.9 *	2.6	3.6 *	2.5	7.5
-1.5 m	8.7 *	8.1 *		9.8 *	9.2 *	7.1 *	5.1	5.1 *	3.4			3.9 *	2.8	7.0
-3.0 m				7.1 *	6.6 *	5.4 *	5.0	3.6 *	3.4 *			3.4 *	3.2 *	6.0
-4.5 m														

The table values refer to ISO 10567 for excavator equipped with bucket. The indicated load is no more than 87% of hydraulic system lift capacity or 75% of static tipping load. Values marked with an asterisk are limited by the hydraulic system.

E195B LIFTING CAPACITY

3100 mm DIPPERSTICK

VALUES ARE EXPRESSED IN TONNES

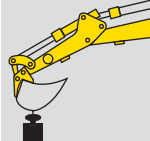
	RADIUS OF LOAD												
	1.5 m		3.0 m		4.5 m		6.0 m		7.5 m		AT MAX. REACH		REACH m
	FRONT	SIDE	FRONT	SIDE	FRONT	SIDE	FRONT	SIDE	FRONT	SIDE	FRONT	SIDE	

E195BEL ONE-PIECE BOOM

HEIGHT													
+7.5 m							2.6*	2.4*			2.0*	1.9*	6.2
+6.0 m							3.4*	3.2*			1.9*	1.8*	7.3
+4.5 m							3.7*	3.5*	3.3*	2.5	1.8*	1.7*	8.0
+3.0 m					5.2*	4.9*	4.3*	3.5	3.9*	2.4	1.9*	1.8*	8.4
+1.5 m			10.5*	9.0	6.5*	4.9	4.9*	3.2	4.2*	2.3	2.1*	1.9	8.5
0	4.6*	4.3*	11.2*	8.3	7.5*	4.6	5.5*	3.1	4.2	2.2	2.4*	1.9	8.3
-1.5 m	7.3*	6.8*	11.8*	8.2	7.7*	4.4	5.6*	3.0	4.2	2.2	2.9*	2.0	7.8
-3.0 m	10.3*	9.6*	10.6*	8.2	7.2*	4.4	5.2*	3.0			4.0*	2.4	6.9
-4.5 m	13.5*	12.6*	8.2*	7.7	5.7*	4.6					4.2*	3.3	5.6

E195BEL TRIPLE ARTICULATION

HEIGHT													
+7.5 m							2.4*	2.2*			2.0*	1.9*	6.0
+6.0 m							3.6*	3.4*			1.9*	1.8*	7.2
+4.5 m					4.8*	4.5*	3.9*	3.6*	3.1*	2.5	1.8*	1.7*	7.8
+3.0 m			8.6*	8.0*	5.6*	5.2*	4.1*	3.5	3.2*	2.4	1.9*	1.8*	8.2
+1.5 m			11.8*	9.3	7.1*	5.0	4.6*	3.3	3.4*	2.3	2.0*	1.9	8.3
0	4.6*	4.3*	12.1*	8.4	7.7*	4.6	5.1*	3.1	3.6*	2.2	2.4*	1.9	8.0
-1.5 m	7.5*	7.0*	10.9*	8.1	7.3*	4.4	5.2*	2.9	3.7*	2.2	2.9*	2.1	7.6
-3.0 m	10.8*	10.1*	8.1*	7.6*	5.9*	4.3	4.2*	2.9			3.2*	2.5	6.7
-4.5 m			4.4*	4.1*	3.3*	3.1*							

E195BLC ONE-PIECE BOOM

HEIGHT													
+7.5 m							2.6*	2.4*			2.0*	1.9*	6.2
+6.0 m							3.4*	3.2*			1.9*	1.8*	7.3
+4.5 m							3.7*	3.5*	3.3*	2.8	1.8*	1.7*	8.0
+3.0 m					5.2*	4.9*	4.3*	3.9	3.9*	2.7	1.9*	1.8*	8.4
+1.5 m			10.5*	9.8*	6.5*	5.6	4.9*	3.7	4.2*	2.6	2.1*	2.0*	8.5
0	4.6*	4.3*	11.2*	9.8	7.5*	5.3	5.5*	3.5	4.3	2.5	2.4*	2.2	8.3
-1.5 m	7.3*	6.8*	11.8*	9.6	7.7*	5.1	5.6*	3.4	4.3	2.5	2.9*	2.3	7.8
-3.0 m	10.3*	9.6*	10.6*	9.7	7.2*	5.1	5.2*	3.4			4.0*	2.8	6.9
-4.5 m	13.5*	12.6*	8.2*	7.7*	5.7*	5.2					4.2*	3.8	5.6

E195BLC TRIPLE ARTICULATION

HEIGHT													
+7.5 m							2.4*	2.2*			2.0*	1.9*	6.0
+6.0 m							3.6*	3.4*			1.9*	1.8*	7.2
+4.5 m					4.8*	4.5*	3.9*	3.6*	3.1*	2.9	1.8*	1.7*	7.8
+3.0 m			8.6*	8.0*	5.6*	5.2*	4.1*	3.8*	3.2*	2.8	1.9*	1.8*	8.2
+1.5 m			11.8*	10.8	7.1*	5.7	4.6*	3.7	3.4*	2.6	2.0*	1.9*	8.3
0	4.6*	4.3*	12.1*	9.9	7.7*	5.3	5.1*	3.5	3.6*	2.5	2.4*	2.2*	8.0
-1.5 m	7.5*	7.0*	10.9*	9.5	7.3*	5.0	5.2*	3.3	3.7*	2.5	2.9*	2.4	7.6
-3.0 m	10.8*	10.1*	8.1*	7.6*	5.9*	5.0	4.2*	3.3			3.2*	2.8	6.7
-4.5 m			4.4*	4.1*	3.3*	3.1*							

The table values refer to ISO 10567 for excavator equipped with bucket. The indicated load is no more than 87% of hydraulic system lift capacity or 75% of static tipping load. Values marked with an asterisk are limited by the hydraulic system.

PARTS & SERVICE



The New Holland dealer network is, in itself, the best guarantee of continued productivity for the machines it delivers to its customers. New Holland service technicians are fully equipped to resolve all maintenance and repair issues, with each and every service point providing the high standards they are obliged to observe under New Holland's stringent quality guidelines. The New Holland global parts network ensures fast, reliable, replacement parts for less downtime, increased productivity and, of course, profitable operation for its customers.

FINANCIAL SERVICES

A critical business partner and leading finance solutions provider, CNH Capital is making it easier than ever for you to acquire and finance top quality construction equipment.

Whether you are operating your own equipment, or managing a fleet of several hundred units, CNH Capital's focus is on you, our customer, your business success and the success of the dealer network that supports you.

By listening to your needs, and those of our construction equipment dealers, and by offering the right mix of products, flexible terms and competitive finance rates, CNH Capital strengthens the bond between our customers, our dealers and our manufacturing facilities.

When the best equipment deserves the best financing solution, you can count on CNH Capital as a specialist in the field of construction equipment.

With CNH Capital, let us find the best financing solution to meet your needs so you can focus on your day to day business and on getting the very best out of your equipment.



NEW HOLLAND. THE POWER OF A GLOBAL BRAND

New Holland is a global brand with a key position in the Construction Equipment business. It supplies a **complete range of 13 product lines and 80 basic models** split into **Compact line** and **Heavy line**. It operates in all the main markets, such as **Europe, North and Latin America, Africa, Asia and Middle East** with the same technology and under the same logo and brand. It manufactures **durable, safe and productive** machines aimed at supporting customers in developing their own business. **Dealers are company partners**. They play an important role to support the brand in their territories through intense professional relationship with Customers. New Holland is reinforced by its **global alliance with Kobelco**: world leader in hydraulic excavator technology.



AT YOUR OWN DEALERSHIP

The information contained in this brochure is intended to be a general nature only. The NEW HOLLAND KOBELCO CONSTRUCTION MACHINERY S.p.A. company may at any time and from time to time, for technical or other necessary reasons, modify any of the details or specifications of the product described in this brochure. Illustrations do not necessarily show products in standard conditions. The dimensions, weights and capacities shown herein, as well as any conversion data used, are approximate only and are subject to variations within normal manufacturing techniques.

Published by NEW HOLLAND KOBELCO CONSTRUCTION MACHINERY S.p.A.
Printed in Italy - LEADER Firenze - Cod. 73301 418GB - Printed 05/08

Printed on recycled paper
CoC-FSC 000010 CQ Mixed sources



ELEMENTAL
CHLORINE
FREE
GUARANTEED

FIAT
GROUP



BUILT AROUND YOU



www.newholland.com