

E18SR

DIMENSIONS (mm)

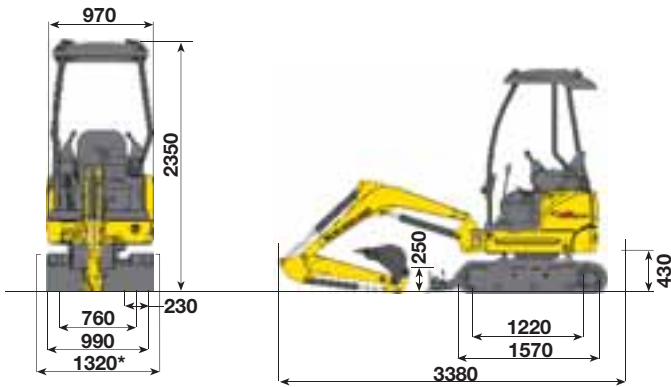

*with extended track gauge

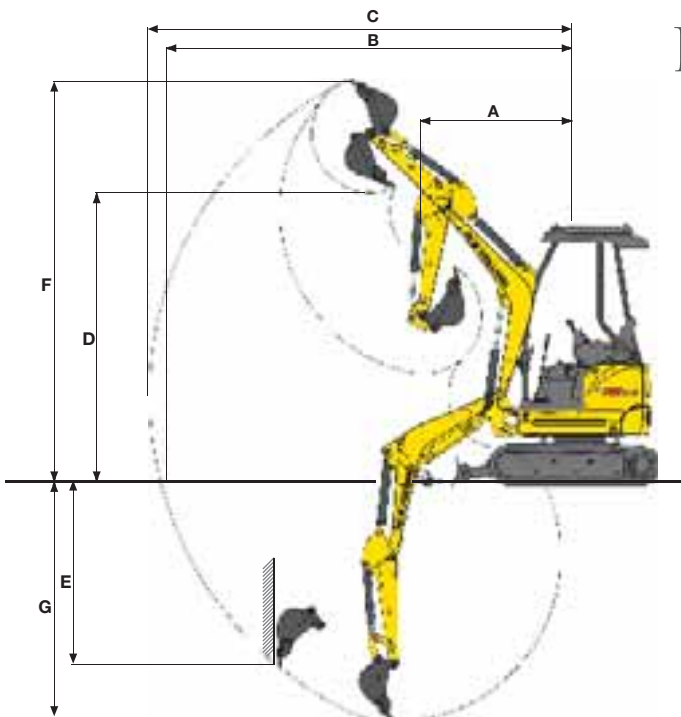

DIGGING PERFORMANCE

| DIPPERSTICK | mm | 980 | 1200 |
|---------------------------|----|------|------|
| A | mm | 1610 | 1680 |
| B | mm | 3790 | 4020 |
| C | mm | 3890 | 4120 |
| D | mm | 2650 | 2750 |
| E | mm | 1660 | 1920 |
| F | mm | 3670 | 3880 |
| G | mm | 2160 | 2370 |
| <i>Blade max lifting</i> | mm | 290 | 290 |
| <i>Blade max lowering</i> | mm | 260 | 260 |
| BREAKOUT FORCE | | | |
| BUCKET | kN | 15.2 | 15.2 |
| DIPPERSTICK | kN | 11.3 | 8.8 |

A product of the global alliance between CNH and KOBELCO

AT YOUR OWN DEALERSHIP

The information contained in this brochure is intended to be a general nature only. The NEW HOLLAND KOBELCO CONSTRUCTION MACHINERY S.p.A. company may at any time and from time to time, for technical or other necessary reasons, modify any of the details or specifications of the product described in this brochure. Illustrations do not necessarily show products in standard conditions. The dimensions, weights and capacities shown herein, as well as any conversion data used, are approximate only and are subject to variations within normal manufacturing techniques.

Published by NEW HOLLAND KOBELCO CONSTRUCTION MACHINERY S.p.A.
Printed in Italy - LEADER Firenze - Cod. 73301 045GB - Printed 10/06

Printed on recycled paper
CoC-FSC 000010 CQ Mixed sources



ELEMENTAL
CHLORINE
FREE
GUARANTEED



BUILT AROUND YOU

www.newholland.com