



NEW HOLLAND

L180 L185

TIER 3A

MAIN SPECIFICATIONS



PERFORMANCE

	L180	L185
SAE operating capacity (kg)	998	1134
Tipping load (kg)	1996	2268
Bucket breakout (kg)	2737	3479
Boom breakout (kg)	1902	2194
Boom raising time - loaded (sec)	3.0	3.0
Boom lowering time - empty (sec)	2.9	2.9
Bucket dump time - loaded (sec)	2.2	2.2
SAE operating weight (kg)	3218	3221



ENGINE TIER 3A

Engine power ISO 14396/ECE R120 (kW/hp)	55/74	61/82
Make/Model	CNH F5C Turbo	CNH F5C Turbo
Displacement (l)	3.2	3.2
Cylinders (n°)	4	4
Diesel tank capacity (l)	87	87

The engine complies with 97/68/EC standards Tier 3A



HYDRAULIC SYSTEM

	Gear	Gear
Pump type		
Pump capacity (l/min)	73	73
Max. pressure (bar)	210	210
Hi-Flow (l/min)	131.4	131.4
Hydraulic oil capacity (l)	57.0	57.0



TRANSMISSION

Type	Hydrostatic	Hydrostatic
Pumps and motors	Axial pistons	Axial pistons
Max low/high speed (km/h)	11.1-18.2	11.1-18.2

UNIQUE COMMON FEATURES OF THE NEW HOLLAND SKID-STEER LOADERS

Plus factors of "Super Boom" skid-steers with patented mechanism

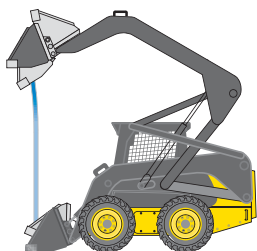

- The low centre of gravity reduces the risk of tipping, giving higher lifting capacity
- There are no structural obstacles, so rear visibility is best-in-class.
- Vertical lifting means maximum reach at maximum height
- Bucket remains level for less spillage



NEW HOLLAND

CONSTRUCTION

BUILT AROUND YOU

MAIN DIMENSIONS

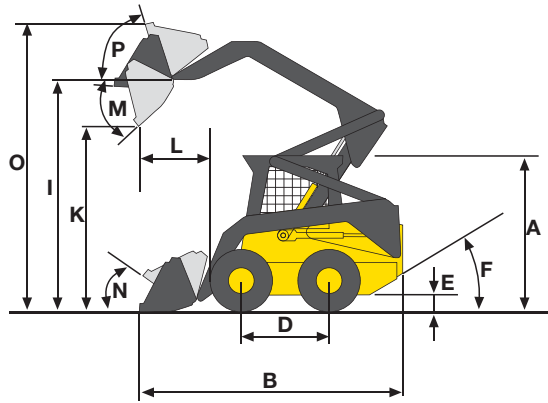
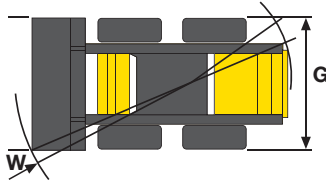

	A mm	B mm	D mm	E mm	F (°)	G mm	I mm	K mm	P (°)	M (°)	N (°)	W mm	L mm	O mm
L180	1960	3520	1220	200	28.4	1810	3165	2540	76	45	37	3835	830	3835
L185	1960	3520	1220	200	28.4	1810	3165	2540	76	45	37	3835	830	3835



L180 & L185 OPTIONAL PILOT CONTROL VERSION

- COMFORTABLE, ENERGY-SAVING OPERATOR POSITION
- COMPLETE MACHINE CONTROLLABILITY
- SMOOTHER, SAFER MOVEMENTS

AT YOUR OWN DEALERSHIP

The information contained in this brochure is intended to be a general nature only. The NEW HOLLAND KOBELCO CONSTRUCTION MACHINERY S.p.A. company may at any time and from time to time, for technical or other necessary reasons, modify any of the details or specifications of the product described in this brochure. Illustrations do not necessarily show products in standard conditions. The dimensions, weights and capacities shown herein, as well as any conversion data used, are approximate only and are subject to variations within normal manufacturing techniques.

Published by NEW HOLLAND KOBELCO CONSTRUCTION MACHINERY S.p.A.
Printed in Italy - LEADER Firenze - Cod. 73301 447GB - Printed 07/08

Printed on recycled paper
CoC-FSC 000010 CQ Mixed sources



ELEMENTAL
CHLORINE
FREE
GUARANTEED

FIAT
GROUP



BUILT AROUND YOU



www.newholland.com