



# NEW HOLLAND

## W170<sub>B</sub> W170<sub>BTC</sub>



	W170B	W170BTC
MAXIMUM POWER	145 kW - 194 hp	
MAX OPERATING WEIGHT	14 840 kg	14 670 kg
BUCKET CAPACITY	2.4 - 2.8 m <sup>3</sup>	2.4 - 2.5 m <sup>3</sup>

 **NEW HOLLAND**

**CONSTRUCTION**

**BUILT AROUND YOU**

# W170B THE POWER

## NEW TIER 3A COMMON RAIL ENGINE



This new CNH Common Rail engine is a jewel of technology, designed to reduce fuel consumption and pollution. The Common Rail system assures the injection of fuel in the cylinders at a very high pressure, optimising its nebulization and its mix with an increased quantity of turbocharged and aftercooled air, thus promoting a perfect and total fuel combustion. Moreover, the **EEMS** (Engine Electronic Management System) controls the “right moment” to introduce the “right quantity” of fuel in the cylinders. These features provide **higher engine efficiency and lower fuel consumption** and, thanks to the **EGR** (Exhaust Gas Recirculation), part of the exhaust gas is reintroduced in the cylinders, to reduce the combustion temperature, therefore contributing to the **reduction of Particulate and NOx emissions**, the production of which are proportional to the combustion temperature.

A particular feature of this electronically controlled CNH engine is its **multiple work mode functionality**. The operator can select one of the following electronically pre-set power modes, depending on the type of job in hand:

**Maximum power:** 145 kW/194 hp, for very tough conditions

**Standard power:** 136 kW/182 hp, for normal loading conditions

**Economy power:** 117kW/ 157 hp, for light load and carry applications.

An **Automatic power mode** can also be selected to automatically match the engine power curve, between maximum power and standard power, to the machine application when they change often.

This engine cuts maintenance time and saves fuel thus minimising operating costs. A new, durable, efficient, comfortable and economic power plant which contributes to increased profits.



# OF DURABILITY & INNOVATION

## A.C.S. (Advanced Cooling System)

The exclusive New Holland Cooling Module

This exclusive Cooling Module looks like a cube positioned in the centre of the machine. All radiators are located around three sides of this cube to optimise both space and cooling effect. The coolant radiator is on the left-hand side while the hydraulic oil and transmission oil radiators are positioned in parallel on the opposite side. The radiator of the engine aftercooler and the air conditioner condenser are on the cube top, also fitted in parallel. To optimise the cooling effect of a fresh and clean air flow, the hydraulic oil tank is built inside the cube and can be easily reached thanks to the hinged liftable condenser of the airconditioning system.

The position of the hydraulic tank, high above the pumps avoids the risk of cavitation, increasing pump durability.

## CENTRALLY MOUNTED COOLING MODULE

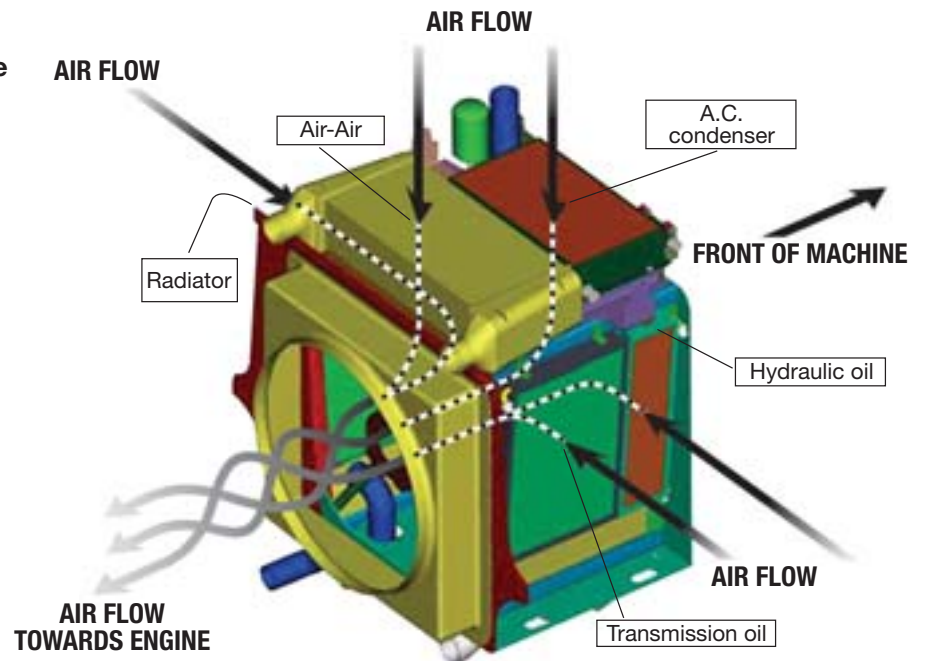

The variable speed hydrostatic fan, with eight plastic blades, is automatically actuated by a thermostatic sensor, drawing fresh and clean air from outside through the radiators and the hydraulic oil tank. A switch in the cab allows the operator to select the fan counter rotation for easy and automatic radiator cleaning. **A really comfortable, durable and efficient innovation offered by New Holland.**

## OUTSTANDING BALANCE

The introduction of the compact and centrally mounted **Cooling Module** results in a wider free space in the back of the rear frame. This innovative solution has allowed the New Holland engineers to position the engine and its components all the way back on the rear frame. Consequently, the centre of gravity is also moved backwards, in a more convenient position to better counterbalance the loading effect. A modern engine hood, which enhances rear visibility, has also been added. Optimum stability with less "dead" weight and better rear visibility means greater operator safety and confidence, shorter cycle times and higher productivity, all of which add up to higher profitability.



# W170B THE POWER

## INTEGRATED HYDRAULIC AND STEERING SYSTEMS



The hydraulic system of the W170B is fed by two variable displacement, axial pistons pumps mounted in series and **Load Sensing** regulated.

One pump delivers 103 l/min to the front loader only, at a maximum pressure of 250 bars. The second pump, with the same delivery and pressure, prioritizes its flow to the steering system via a **demand valve**. If steering is not required, all the hydraulic oil, including the flow from the second pump, is available for the front loader to provide fast, efficient and productive cycles. A small gear pump driven by an electric motor, which automatically switches on in case of engine shutoff, provides **emergency steering**, for operator safety and comfort.



The **closed centre** pilot control valve allows simultaneous under every load and engine speed condition: an outstanding feature so far offered only by best in market hydraulic excavators. Controls are power assisted, with electromagnetic detent and the loader section of the control valve includes floating function.

Hydraulic and Steering: an integrated system which features operator comfort as well as top class safety, controllability and efficiency.

# OF EFFICIENCY & ECONOMY

## MAINTENANCE AND SERVICE



**T**he W170B is designed for simple and easy maintenance and service procedures thanks to its excellent ground level access to all the most important components and to the new high-tech digital display located on the dashboard, which keeps the operator fully aware of all machine main functions, such as engine and transmission diagnostics, error reporting and warning prompts.

**W**ide side panels, that open and close with a seagull wing movement, are light to lift and automatically self-locking in a safety position thanks to compressed air cylinders.



**T**hey give immediate access to most of the engine components, including the high pressure injection pump, alternator, fuel/water separator, engine oil filter, fuel filter, air filter and the engine electronic control panel. Access to the hydraulic tank is provided by a third liftable panel, located on the top of the engine hood, behind the cab.



**G**rouped together in a protected and easily-accessible remote position on the rear left side of the machine are the engine oil, coolant and hydraulic oil valves, allowing easy and ecological discharge of fluids. All this adds up to maximum comfort, safety, efficiency and economy in the day-to-day use of the New Holland W170B.

# W170B THE POWER

## COMFORT AND SAFETY SPACE LAB CAB

The New Holland W170B is now equipped with a completely new designed and advanced cab featuring outstanding internal and external improvements.

“Space” means that:

- access to the cab has been improved thanks to the **580mm** wide door (80mm wider), which can be locked back at 180 deg., and to the new, wider inclined stair with larger anti-slip steps.



- internal volume has been **increased by 13%** and the glass are enhanced to provide perfect bucket and 360 deg. visibility.

- the steering column is tiltable and includes a high-tech dashboard, enabling easy functional checks from every position.

- the new contoured and suspended seat, adjustable in all directions, incorporates a retractable seat belt and adjustable armrests. It can be supplied with optional head rest to let the operator work with maximum comfort in an extremely low noise atmosphere.



“Lab” means an advanced laboratory where:

- vital information about the main components are provided in real time by the new onboard computer and displayed in the new, multilanguage, high-tech, digital LCD screen located on the dashboard just in front of the operator for easy reading;

- the "car standard" cab features an **integrated ROPS and FOPS structure** with tinted safety glass.

- standard pressurisation, optional climatization and FM radio, low noise level and modern and elegant interiors provides the operator with pleasant and comfortable working conditions, regardless of the external weather conditions.

# OF SAFETY & COMFORT



A machine cab several steps ahead of the rest in terms of state-of-the-art technology. A cab designed to provide maximum operator comfort and safety, allowing him to fully concentrate on the job in hand for better performance and higher productivity.



# W170B SPECIFICATIONS



## ENGINE TIER 3A

Maximum power (ISO 14396/ECE R 120-SAE J 1995) .....145 kW/194 hp  
 Net flywheel power (SAE J1349).....137kW/184 hp  
 Rated engine speed .....2000 rpm  
 Make and model .....CNH 667TA/EED  
 Type.....Diesel, Common rail, turbo, aftercooler, electronic injection  
 Total displacement .....6.7 l  
 N° of cylinders .....6  
 Bore x stroke .....104 x 132 mm  
 Maximum torque at 1400 rpm .....86.2 daNm  
 Lubrication with gear pump

*The engine conforms to European requirements for "low exhaust emission" in accordance with directive 97/68/EC TIER 3A.*



## ENGINE MULTIPLE WORK MODES

The latest generation CNH TIER 3A common rail engine, electronically controlled, features **multiple work modes**. According to the type of application, the operator can select the following engine power modes:

- **Maximum power** .....145kW/194 hp, for very tough conditions
- **Standard power** .....136kW/182 hp, for normal loading conditions
- **Economy power** .....117 kW/157 hp, for light load & carry applications
- **Automatic power mode:** to automatically match the power curve to the application.

Perfect electronic control to get the best performances in every type of job while contributing to reduced fuel consumption.



## ELECTRICAL SYSTEM

Voltage .....24 V  
 Batteries, in series .....2  
 - Capacity .....155 Ah  
 - Type .....maintenance-free  
 Starter motor .....7.8 kW  
 Alternator capacity .....65 A



## TORQUE CONVERTER

Type .....single stage / single phase  
 Torque multiplication ratio .....2.81 : 1



## TRANSMISSION

Type: PowerShift countershaft design with four forward and three reverse speeds

Control: single lever electric "fingertip" type.

Forward speeds.....km/h  
 1° .....7.6  
 2° .....13.4  
 3° .....24.6  
 4° .....38.0  
 Reverse speeds  
 1° .....8.0  
 2° .....14.0  
 3° .....25.8  
 with 20.5-25 tyres

Safety device prevents engine starting in gear

**Electronic Transmission System (ETS):** allows the operator to dedicate attention to the work cycle.

The on-board computer automatically finds the right gear in relation to the type of work.

**"HOLD"** function to maintain selected speed with the machine operating on a slope.

**"KICK-DOWN"** function to shift from 2nd to 1st gear when high pushability is required.

**"DOWNSHIFT"** function to select the most suitable speed with the machine on a slope. Low gears favour the use of the engine brake function and consequently reduce brake use.

Forward and reverse control switch.



## AXLES

Rigid front axle, oscillating rear axle designed for heavy duty applications

Rear axle oscillation.....24°

Rear wheel vertical travel .....450 mm

"Limited slip" differentials supplied standard.

Hermetically sealed final drives and wet disc brakes



## BRAKES

**Service brakes** .....self-adjusting

Type .....wet disc brakes on all four wheels

Servo-assisted hydraulic brake circuit.

Independent circuit for each axle.

Control pedal located to left of steering column.

Electrical transmission disengagement switch.

The brake circuit complies with the following international standards:

ISO 3450, CEE 71/320, SAE J1473

**Parking brake:** spring applied hydraulically released caliper disc brake on transmission output shaft.

Electrical control by means of switch in cab.



## TYRES

Type .....tubeless

Radial .....20.5-25 RT-3B

20.5-25 RM-94A

20.5-25 XHA

20.5-25 GP-2B

20.5-25 RL-5K

20.5-25 XLD-D2

550/65-25GP-3D



## HYDRAULIC SYSTEM

Type .....load sensing circuit, closed centre

Pumps.....2 - variable displacement -axial pistons

feeding the integrated implement and steering system

Max. flow delivery.....206 l/min

Max. working pressure .....250 bar

Control valve .....2 spool

3 spool

Control .....piloted dual lever  
piloted, single lever

Double-acting hydraulic cylinders

Booms .....2  
Bore x stroke .....121 x 828 mm  
Bucket.....1  
Bore x stroke .....146 x 630 mm

Operating time

Lift .....5.6 s  
Lower empty.....3.3 s  
Dump .....2.4 s

Hydraulic lines and connecting flanges are equipped with O-ring seals.

**L.T.S. device**

Load Travel Stabiliser. Invaluable for loading and transport on uneven terrain.



**STEERING**

Type.....**Orbitrol**, hydraulically actuated with priority valve  
Pump.....utilises one of the hydraulic system pumps  
Max. flow rate .....120 l/min  
Max. working pressure .....248 bar  
Cylinders .....2, double acting  
Bore x stroke .....76 x 485 mm  
Emergency steering circuit with electric motor activated by the onboard computer.



**CAB**

ROPS/FOPS modular cab.

Excellent, all-round, visibility. The ROPS/FOPS cab complies with the following standards:

ROPS - EN 13510

FOPS - EN ISO 3449



**CAPACITIES**

	Litres
Lube oil .....	15
Coolant .....	37
Fuel tank .....	253
TRANSMISSION	
Hydraulic system .....	193
AXLES.....	30/27

**DIMENSIONS mm**

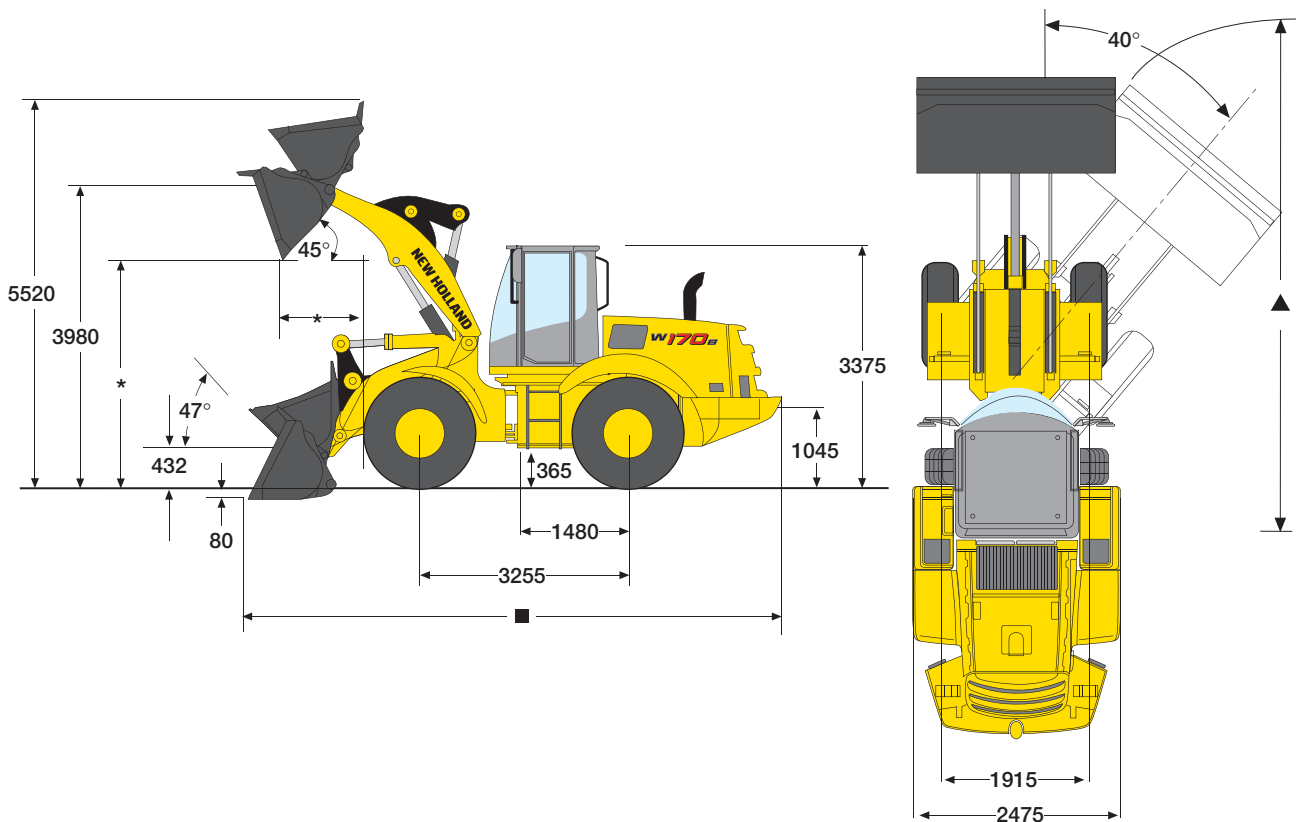

# W170B

## PERFORMANCE

### GENERAL PURPOSE

BUCKET TYPE		WITH TEETH AND SEGMENTS		WITH CUTTING EDGE EXTENSION		WITH TEETH		WITH Q.C.**	
						TEETH	CUTTING EDGE		
Bucket capacity	m <sup>3</sup>	2.6	2.8	2.6	2.8	2.5	2.7	2.4	2.5
Bucket weight	kg	1175	1250	1130	1200	1095	1165	1550	1590
Bucket width	mm	2475	2690	2475	2690	2475	2690	2475	2475
Dump height at 45° *	mm	2780	2780	2865	2865	2780	2780	2655	2740
Reach at 45° *	mm	1105	1105	1030	1030	1105	1105	1250	1170
Overall length (bucket on ground) ■	mm	7760	7760	7645	7645	7760	7760	7940	7825
Turning radius ▲ (bucket at carry position)	m	6.2	6.3	6.2	6.3	6.2	6.3	6.3	6.3
Breakout force	daN	12970	12935	14310	14270	13050	13015	11020	11940
Static tipping load (with standard cwt): 0°	kg	12620	12540	12710	12640	12735	12660	11210	11320
40°	kg	11110	11035	11200	11130	11225	11150	9830	9920
Max operating weight	kg	13980	14050	13935	14005	13900	13970	14355	14390
Static tipping load (with heavy counterweight): 0°	kg	13650	13570	13740	13670	13760	13690	12215	12325
40°	kg	11980	11905	12070	12000	12095	12020	10680	10770
Max operating weight	kg	14430	14500	14385	14455	14350	14420	14805	14840

\* At bucket cutting edge

\*\* With Quick Coupler

## PERFORMANCE "LONG BOOM"

### GENERAL PURPOSE

BUCKET TYPE		WITH CUTTING EDGE EXTENSION
Bucket capacity	m <sup>3</sup>	2.7
Bucket weight	kg	1280
Bucket width	mm	2700
Dump height at 45°	mm	3255
Reach at 45° (at 2130 mm height)	mm	1985
Overall length (bucket on ground)	mm	8090
Overall height (bucket raised)	mm	5660
Turning radius (at bucket edge)	m	6.5
Breakout force	kg	13430
Static tipping load: 0°	kg	10145
40°	kg	8730
Operating weight	kg	14590



Note: All performance data and specifications based on a unit with 20.5-25 XTLA Radial tyres and ROPS cab.  
All data is obtained in compliance with the latest applicable SAE Recommended Practices including J732c, J742b and ISO 6746/1, ISO 6746/2 and ISO 8313.

# W170BTC

WITH QUICK COUPLER

## WITH BUCKET - DIMENSIONS mm

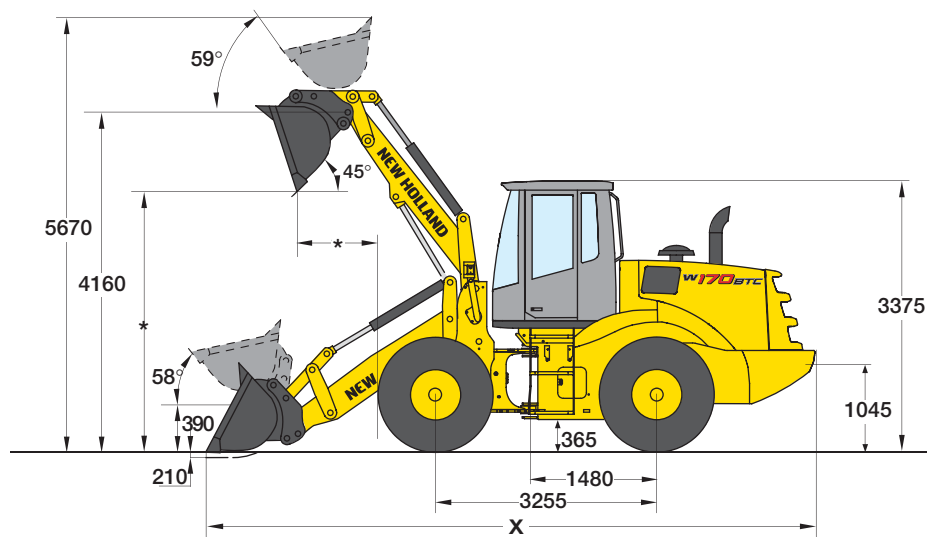

## PERFORMANCES

### GENERAL PURPOSE

BUCKET TYPE		WITHOUT TEETH	WITH TEETH	WITH CUTTING EDGE	WITH TEETH AND SEGMENTS
Bucket capacity	m <sup>3</sup>	2.4	2.4	2.5	2.5
Bucket weight (including Quick Coupler)	kg	1475	1590	1630	1673
Bucket width (maximum)	mm	2475	2475	2475	2475
Dump height at 45° *	mm	2840	2690	2770	2690
Reach at 45° *	mm	1225	1360	1270	1360
Overall length (bucket on ground) X	mm	8020	8240	8120	8240
Turning radius (bucket at carry position)	m	6.2	6.3	6.2	6.3
Breakout force	daN	12850	11195	12020	12100
Static tipping load:					
0°	kg	13210	13050	13000	12955
40°	kg	11455	11290	11245	11225
Max operating weight	kg	14510	14630	14665	14670

\* At bucket cutting edge

## WITH PALLET FORK - DIMENSIONS mm

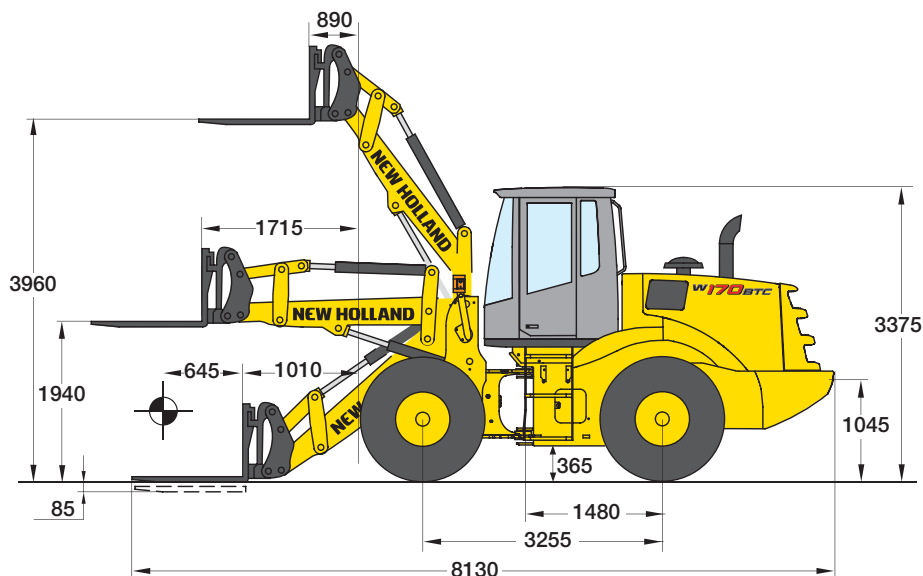

## PERFORMANCES

PALLET FORK		
Fork length	mm	1220
Fork weight (including Quick Coupler)	kg	690
Ground to top of tine clearance	mm	3960
Reach with arms horizontal	mm	1715
Overall length (tines on ground)	mm	8130
Operating load		
- rough terrain	kg	4260
- firm and level ground	kg	5680
Static tipping load (level arms, level fork, 600 mm load center):		
0°	kg	8410
40°	kg	7100
Operating weight	kg	13730

Note: All performance data and specifications based on a unit with 20.5-25 XTLA Radial tyres and ROPS cab. All data is obtained in compliance with the latest applicable SAE Recommended Practices including J732c, J742b and ISO 6746/1, ISO 6746/2 and ISO 8313.

# STANDARD EQUIPMENT

- 70 A alternator voltage regulator
- Antifreeze
- Automatic return-to-dig
- Two batteries of 160 Ah each
- Bucket and lift levers with hydraulic power assist and electromagnetic detent
- Bucket position indicator
- Centrally located fuse box
- A.C.S., Advanced Cooling Module centrally mounted with integrated hydraulic oil tank for: - transmission oil - engine coolant - hydraulic oil - air to air aftercooler - air conditioner condenser (if equipped)
- Electrical disconnect
- Emergency steering
- Four-wheel drive
- Front and rear halogen flood lights
- Full flow hydraulic system with 10 micron filter
- Horn
- Hydraulic driven fan
- Hydraulic wet disc brakes
- Instrumental Cluster:  
**Analog Gauges:**  
- Transmission Temperature - Engine Coolant Temperature  
- Hydraulic Oil Temperature - Fuel Level

#### Audible and Visual alarms:

- Cautionary and critical Levels - Directional/Brights Indication
- Low Fuel - Directional Signals - Low Oil Pressure

#### LCD Screen:

- Hour Meter - Time - F/N/R Indication - Trip computer
- Metric/English - Warning Prompts - Engine Speed
- Automatic Trans Indication - DeClutch Indication
- Fuel Consumption - Engine Diagnostic - Error Reporting
- Travel Speed - Current Gear Selection - Engine Mode Indication
- Multiple Languages - Transmission Diagnostics
- Limited slip differentials axles
- Planetary axles
- Power steering
- Remote drain points
- Retractable seat belt
- ROPS/FOPS Cab
- Single lever electrically actuated proportional Powershift transmission
- Side covers
- Spring applied hydraulic releases disc parking brake
- Suspended and adjustable cloth seat
- Tail lights and stop lights combined
- Tilt steering column
- Tubeless tires
- Two-element dry-type air cleaner

# OPTIONS

- 2 spool valve with joystick
- 3 spool valve with 3 levers
- 3 spool valve with joystick and 1 lever
- Air suspended and fully adjustable cloth seat
- Automatic Airconditioner
- Buckets selection with teeth and cutting edge
- Cold weather package
- Fire extinguisher
- Full view air precleaner
- Head rest
- Heavy Duty Counterweight

- Italian homologation
- LTS Load Travel Stabiliser
- Quick Coupler
- Radio
- Rotating beacon
- Transmission guard
- Transfer fuel pump kit
- Tool box
- TUV homologation
- Wide choice of tyres
- Wide fenders with LH and RH steps

Note: standard and optional equipment may vary by country. Consult your NEW HOLLAND dealer for specific details.

#### AT YOUR OWN DEALERSHIP

The information contained in this brochure is intended to be a general nature only. The NEW HOLLAND KOBELCO CONSTRUCTION MACHINERY S.p.A. company may at any time and from time to time, for technical or other necessary reasons, modify any of the details or specifications of the product described in this brochure. Illustrations do not necessarily show products in standard conditions. The dimensions, weights and capacities shown herein, as well as any conversion data used, are approximate only and are subject to variations within normal manufacturing techniques.

Published by NEW HOLLAND KOBELCO CONSTRUCTION MACHINERY S.p.A.  
Printed in Italy - LEADER Firenze - Cod. 30 340GB - Printed 04/09

Printed on recycled paper  
CoC-FSC 000010 CQ Mixed sources



ELEMENTAL  
CHLORINE  
FREE  
GUARANTEED



BUILT AROUND YOU

www.newholland.com