



MINIMUM SWING RADIUS EXCAVATOR **CX75**



Engine Horsepower	40 kW - 50 hp
Operating weight (max.)	7.9 t
Bucket capacity	0.18 m ³ to 0.34 m ³

P R O F E S S I O N A L P A R T N E R

SPECIFICATIONS

ENGINE

Model _____ Isuzu AU-4LE2X
Type _____ 4-stroke turbocharged
Cylinders _____ 4
Bore/Stroke _____ 85 x 96 mm
Displacement _____ 2179 cc
Fuel injection _____ Direct
Fuel injection pump _____ Mechanical
Fuel _____ Diesel
Fuel filter _____ In-line strainer
Cooling _____ Liquid
Horsepower per SAE J1349
Net _____ 54 hp (40 kW) @ 2000 rpm
Maximum torque @ 1500 rpm
Net _____ 210 Nm

BOOM/ARM

Boom 3.87 m

Boom w/arm cylinder & plumbing _____ 492 kg
Hoist cylinders (1) _____ 103 kg ea
Total weight _____ 595 kg

Arm 1.71 m

Bare arm _____ 140 kg
Bucket cylinder linkage & plumbing _____ 115 kg
Total weight _____ 255 kg

Arm 2.12 m

Bare arm _____ 185 kg
Bucket cylinder linkage & plumbing _____ 115 kg
Total weight _____ 300 kg

Offset boom 3.92 m

Boom w/arm cylinder & plumbing _____ 1902 kg
Hoist cylinders (1) _____ 103 kg ea
Total weight _____ 1005 kg

Arm Offset boom 1.75 m

Bare arm _____ 141 kg
Bucket cylinder linkage & plumbing _____ 120 kg
Total weight _____ 261 kg

UNDERCARRIAGE

Number of rollers
Top, each track _____ 1
Bottom, each track _____ 5
Number of shoes
Triple grouser - each side _____ 39
Link pitch _____ 154 mm
Gradeability _____ 70%

HYDRAULICS

Pumps (2) _____ Variable displacement axial piston design

Capacity

Maximum _____ 68 L/min

System relief pressure

Standard _____ 29.4 MPa

Control valves

1-spool blade and auxiliary

4-spool section for right track travel, boom, bucket and arm

5-spool section for left track travel, boom, auxiliary, swing and arm

Boom anti-drift valves

Pilot control hydraulic system

Pump (1) _____ Gear design

Maximum capacity _____ 21.4 l/min

Relief pressure _____ 4.2 MPa

Swing

Motor (1) _____ Fixed displacement axial piston design

Speed _____ 0-9.5 rpm

Brake _____ Mechanical disk

Travel

Motor (2) _____ Two-speed axial piston design

Final drive _____ Planetary gear reduction

Drawbar pull _____ 59 kN

Travel Speeds - 2 Auto shift high to low

Forward/Reverse

Low _____ 3.4 km/h

High _____ 5.1 km/h

Travel control valve

Dual stage relief and counter-balance design

HYDRAULIC CYLINDERS

Boom cylinders (1)

Bore diameter _____ 110 mm

Rod diameter _____ 70 mm

Stroke _____ 911 mm

Arm cylinder (1)

Bore diameter _____ 95 mm

Rod diameter _____ 60 mm

Stroke _____ 797 mm

Bucket cylinder (1)

Bore diameter _____ 85 mm

Rod diameter _____ 55 mm

Stroke _____ 665 mm

ELECTRICAL

Voltage _____ 12 volts, negative ground

Alternator _____ 50 amp

Batteries (1) _____ Low-maintenance 64 Ah

SERVICE CAPACITIES

Hydraulic tank

Refill capacity _____ 50 l

Total system _____ 97 l

Final drive (per side) _____ 1.1 l

Swing drive _____ 2.2 l

Engine

w/filter change _____ 9.0 l

Fuel _____ 100 l

Radiator _____ 10.2 l

OPERATING WEIGHT

With 1.71 m arm, 450 mm track shoes, 210 kg bucket, 75 kg operator, full fuel and standard equipment _____ 7919 kg

PERFORMANCE DATA

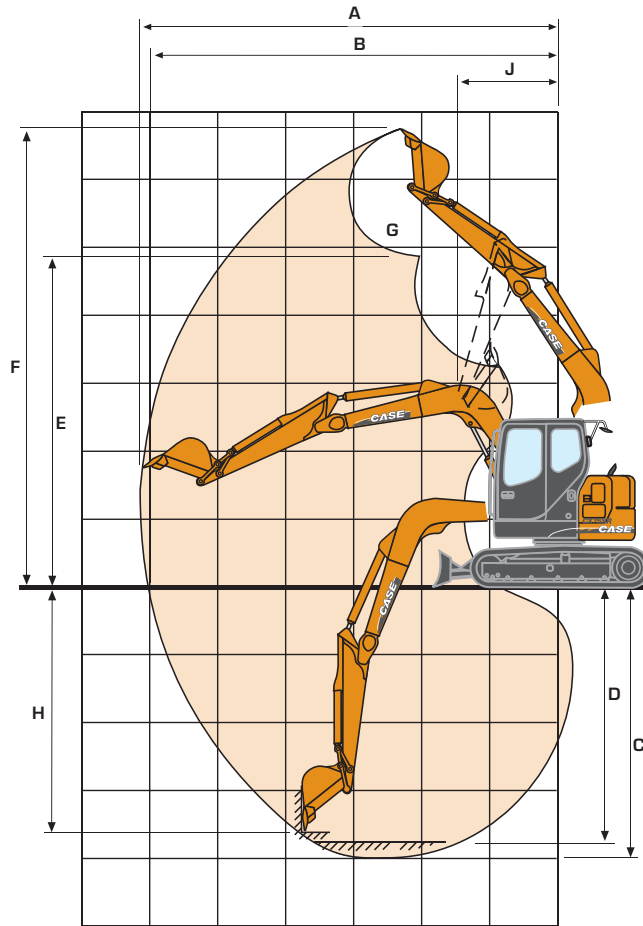

DIMENSIONS		1.71 m	2.12 m	1.75 m Offset Boom	
A	Maximum dig radius	m	6.52	6.90	6.49
B	Dig radius at groundline	m	6.39	6.77	6.36
C	Maximum dig depth	m	4.14	4.54	4.19
D	Dig depth - 2.44 m level bottom	m	3.81	4.26	3.81
E	Dump height	m	5.25	5.54	5.15
F	Overall reach height	m	7.33	7.62	7.20
G	Bucket rotation		177°	177°	177°
H	Vertical straight wall dig depth	m	3.64	4.10	3.26
J	Minimum swing radius	m	1.79	2.09	2.23
Arm digging force					
	Standard	kN	38.3	34.0	39.4
Bucket digging force					
	Standard	kN	56.9	56.9	56.9
Dozer blade cutting edge					
	Max. height	kN	0.42	0.42	0.42
Dozer blade cutting edge					
	Max. depth	kN	0.21	0.21	0.21
	Dozer blade width	kN	2.32	2.32	2.32



LIFTING CAPACITY

Values are expressed in kilos

Front 360°	REACH							
	3.05 m		5.57 m		6.10 m		At max reach	

1.71 m Arm, 210 kg bucket, 1370 kg counterweight operating in "Standard" Mode, blade down.

6.10 m							1475*	1475*	3.94
4.57 m	1588*	1588*					1316*	1112	5.44
3.05 m	2133*	2133*	1747*	1452			1294*	863	6.10
1.52 m	3085*	2563	2042*	1361			1384*	772	6.30
0 m	3607*	2359	2269*	1271			1588*	817	6.05
-1.52 m	3471*	2314	2223*	1225			1656*	999	5.26
-3.0 m	2700	2382							

Offset Boom with 1.75 m Arm, 210 kg bucket, 1370 kg counterweight operating in "Standard" Mode, blade down.

6.10 m							1385*	1385*	3.89
4.57 m	1543*	1543*					1362*	1067	5.41
3.05 m	2042*	2042*	1611*	1384			1385*	795	6.10
1.52 m	2836*	2405	1884*	1248			1430	681	6.27
0 m	3244*	2088	2065*	1112			1498*	704	6.02
-1.52 m	3154*	2020	2020*	1067			1521*	886	5.23
-3.0 m	2428*	2133							

2.12 m Arm , 191 kg bucket, 1370 kg counterweight operating in "Standard" Mode, blade down

6.10 m							1315*	1315*	4.57
4.57 m			1430*	1430*			1181*	976	5.87
3.05 m	1816*	1816*	1589*	1475			1181*	772	6.50
1.52 m	2859*	2632	1906*	1362	1565*	839	1249*	704	6.68
0 m	3562*	2360	2201*	1271	1633*	794	1407*	727	6.43
-1.52 m	3539*	2292	2246*	1203			1566*	863	5.72
-3.0 m	2995*	2314	1770*	1226					



GENERAL DIMENSIONS

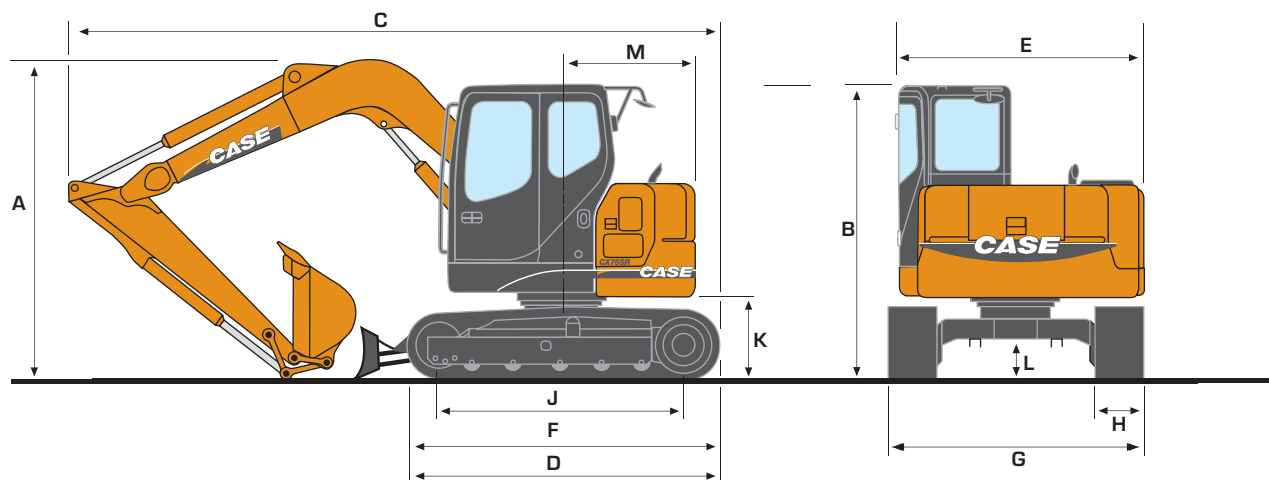

DIMENSIONS		1.71 m	2.12 m	1.75 m Offset Boom	
A	Overall height	m	2.70	2.95	2.97
B	Cab height	m	2.70	2.70	2.70
C	Overall length	m	5.92	5.91	5.9
D	w/o attachment	m	3.28	3.28	3.28
E	Width of upperstructure	m	2.23	2.23	2.23
F	Track overall length	m	2.85	2.85	2.85
G	Track overall width w/450 mm shoes	m	2.32	2.32	2.32
H	Track shoe width	mm	450	450	450
J	Center to center (idler to sprocket)	m	2.21	2.21	2.21
K	Upperstructure ground clearance	m	0.75	0.75	0.75
L	Minimum ground clearance	m	0.36	0.36	0.36
M	Tail swing radius	m	1.24	1.24	1.24
	Dozer blade width	m	2.32	2.32	2.32
	Dozer blade height	m	0.45	0.45	0.45
	Working weight*	kg	7919	7964	8259
	Ground pressure	kPa	35	35	37.0

*With 1460 mm track shoe, 210 kg bucket, 75 kg operator, full fuel and standard equipment.

BUCKETS

GENERAL PURPOSE

SAE capacity	m ³	0.18 to 0.34
Width	m	0.457 to 0.762

DITCHING

SAE capacity	m ³	0.46 to 0.54
Width	m	1.067 to 1.219

CX75

STANDARD EQUIPMENT & OPTIONS

STANDARD EQUIPMENT

Operator's compartment

- Cab with Isomount® system
- Adjustable deluxe seat with
- 76 mm seat belt
- Safety glass
- Air conditioning
- AM/FM Radio w/auto tuner
- Skylight
- Sliding front windows
- Windshield wiper w/washer

Engine

- Isuzu AU-4LE2X diesel
- Tier IV Stage 1 compliant
- Glow plug
- Selectable one touch accelerator/decelerator

Electrical

- Batteries (1) 12-Volt
- Horn

Hydraulics

- ISO pattern pilot controls
- Position mode selector: S
- Variable flow piston pumps
- Neutral pump destroke
- Auxiliary hydraulic valve
- Boom anti-drift valves
- Ultra Clean filtration system

Undercarriage

- Shoes: 450 mm 3-bar, 39 per side
- Track length: 2.85 m
- Track gauge: 1.87 m
- Dozer blade

Track drive

- 2-speed hydrostatic travel
- Disc-type parking brakes

Upperstructure

- Boom: 3.87 m one piece
- Hammer adaptable
- Swing brake

Other

- Counterweight: 1370 kg
- Single key vandal lockup

OPTIONS

Upperstructure

- Arm: 2.18 m
- Offset boom: 3.92 m
- Arm for offset boom: 1.74 m

Uppercarriage

- Track Slides: 600 mm
- Rubber Link Track

Hydraulics

- Auxiliary hydraulics
- Single acting, one pump (includes heavy-duty bucket linkage)
- Double acting, single or dual pump (includes heavy-duty bucket linkage)
- Double acting general purpose for use with thumb kit
- Control pattern selector valve

Other

- Load holding control devices
- Cylinder mounted
- Case/JRB Slide-Loc*
- Hydraulic Coupler

Standard and optional equipment shown can vary by country.

Worldwide Case Construction Equipment Contact Information

EUROPE/AFRICA/MIDDLE EAST:
Centre D'affaires EGB
5, Avenue Georges Bataille - BP 40401
60671 Le Plessis-Belleville - FRANCE

NORTH AMERICA/MEXICO:
700 State Street
Racine, WI 53404 U.S.A.

LATIN AMERICA:
Av. General David Sarnoff 2237
32210 - 900 Contagem - MG
Belo Horizonte BRAZIL

ASIA PACIFIC:
Unit 1 - 1 Foundation Place - Prospect
New South Wales - 2148 AUSTRALIA

CHINA:
No. 29, Industrial Premises, No. 376,
De Bao Road, Waigaoqiao Ftz, Pudong,
SHANGHAI, 200131, P.R.C.

CASE Customer Assistance
00800-2273-7373

The call is free from a land line. Check in advance with your Mobile Operator if you will be charged.

NOTE: Standard and optional fittings can vary according to the demands and specific regulations of each country. The illustrations may include optional rather than standard fittings - consult your Case dealer. Furthermore, CNH reserves the right to modify machine specifications without incurring any obligation relating to such changes.



Conforms to directive 98/37/CE

CASE Construction Equipment

CNH UK Ltd
Unit 4,
Hayfield Lane Business Park,
Field Lane, Auckland,
Doncaster,
DN9 3FL
Tel. 00800-2273-7373
Fax +44 1302 802829

www.casece.com

CASE
CONSTRUCTION